

WEG DAY

2024

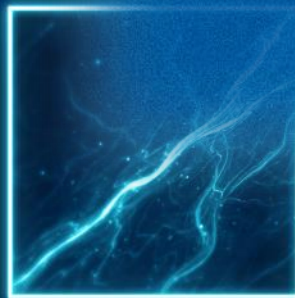

Driving efficiency and sustainability



Estratégia Motores Industriais

RODRIGO FUMO FERNANDES

Diretor Superintendente
WEG Motores Industriais



WEG
DAY
2024

WEG Motores Industriais



+ de **13.000** colaboradores no mundo



+ de **10 mil** motores produzidos por dia

75%

das vendas em 2023 foram de motores elétricos de **alta eficiência**

Distribuição da Receita Global

Motores

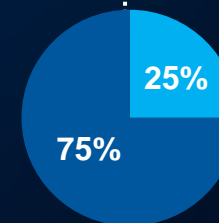

Redutores

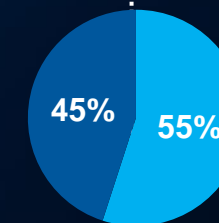

■ Brasil
■ Mercado Externo

+ de
R\$ 710 milhões
em investimentos em 2023

+ de
500.000 m²
de área construída

WEG
DAY
2024

Footprint



Motores Industriais Baixa Tensão WEG

Motores Industriais Baixa Tensão Marathon

Redutores e Motorredutores



Market Share



Motores Industriais Baixa Tensão

WEG + Marathon⁽¹⁾: 15%

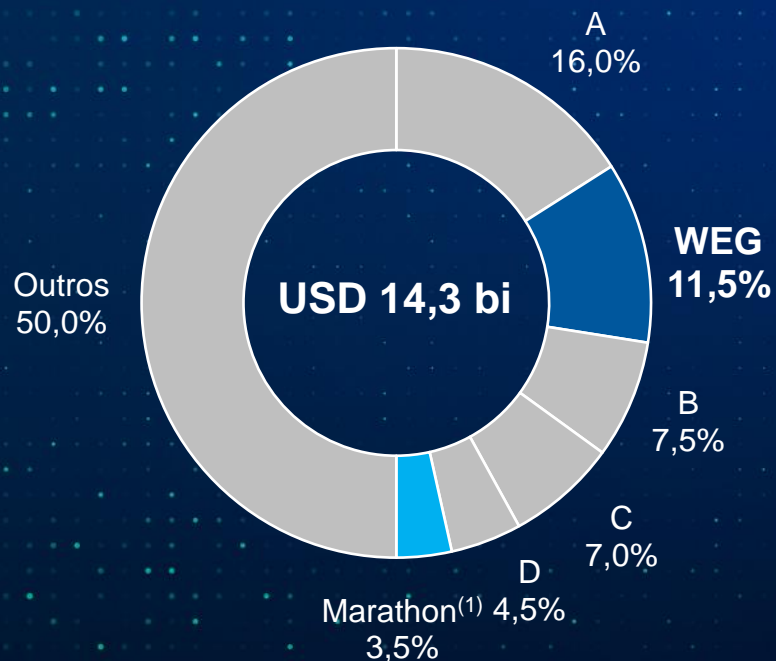

Crescimento de market share

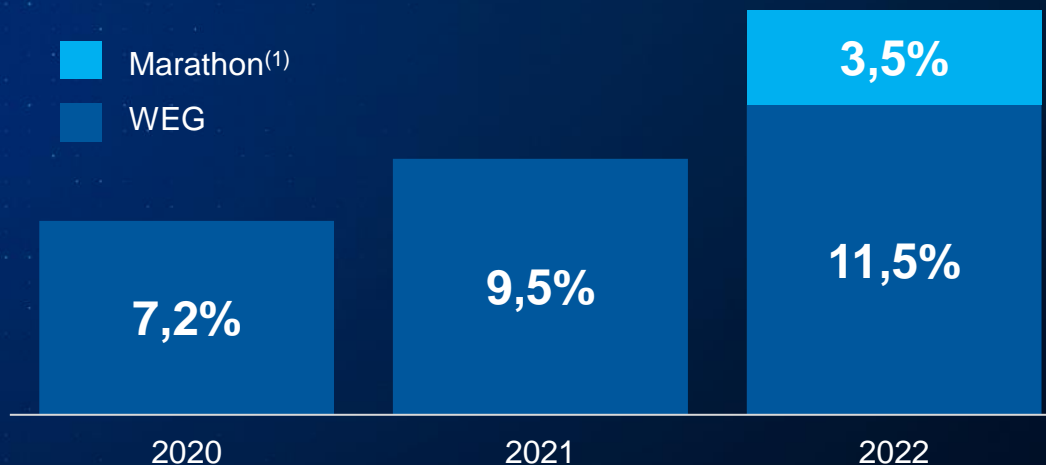

Américas



EMEA

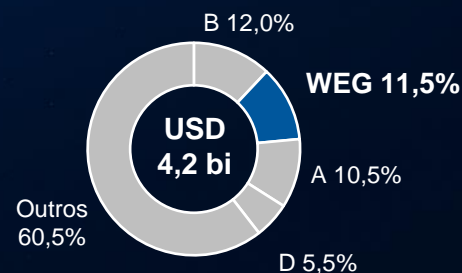

Ásia Pacífico

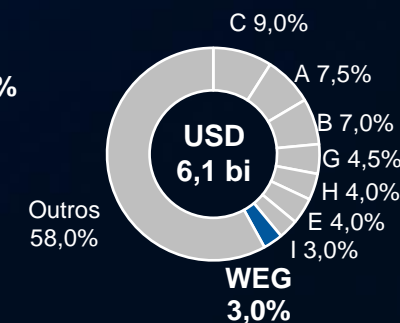

Fonte: Omdia 2023 – LV Motores

(1) Considera as marcas Marathon, Cemp e Rotor



Integração Marathon



115 participantes

3 dias
de evento em
Jaraguá do Sul

21 apresentações

12 horas
de visitas
às fábricas



WEG
DAY
2024

Integração Marathon



Day 01

Closing Date

01 de Maio de 2024

- União WEG e Marathon
- 2.500 colaboradores
- Início da integração

Integration Meeting

17 de Junho de 2024

- Executivos Marathon em Jaraguá do Sul
- Estrutura dos negócios WEG
- Governança, cultura, missão e visão
- Estratégias de integração

Marathon Integration Group

03 de Julho de 2024

- Executivos Marathon e WEG
- Grupo multidisciplinar
- Fórum permanente
- Identificar sinergias
- Melhorias operacionais
- Ganho de competitividade



Estratégia América do Norte



Marca Secular nos Estados Unidos

Forte presença nos setores automotivo, metalúrgico, papel e celulose e HVAC⁽¹⁾ Comerciais

Sinergias e Oportunidades

- Quatro novas fábricas
- Impulsiona a estratégia Motion Drive WEG
- Fornecimento de soluções completas com inversores de frequência
- Fortalece a presença WEG em segmentos importantes
- Ganho de escala pela sinergia entre Marathon Monterrey e WEG México

Wausau, EUA



(1) Sigla em inglês para *Heating, Ventilating and Air Conditioning*, que significa Aquecimento, Ventilação e Ar Condicionado

WEG
DAY
2024

Monterrey, México

Estratégia China



Marca reconhecida em operação desde **1958**

Motores baixa tensão IEC/NEMA e média tensão IEC

Sinergias e Oportunidades

- Inclusão de inversores e redutores WEG nos pacotes de fornecimento da Marathon
- Produção de motores para exportação
- Conhecimento e experiência da equipe Marathon local
- Ganhos com a sinergia entre Marathon e WEG China

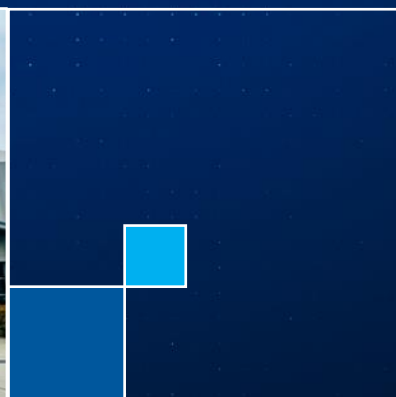

Wuxi, China

WEG
DAY
2024

Estratégia Índia



Ahmedabad, Índia

Sinergias e Oportunidades

- Duas novas plantas, em Kolkata e Ahmedabad
- Maior proximidade aos principais clusters industriais da Índia
- Participação em importantes segmentos como *Flame Proof*, *Smoke Extraction*, *Crane Duty*, *Slipring*, *Brake Motor*
- Ampliação da rede de Revendedores e Service Centers



Kolkata, Índia

WEG
DAY
2024

Estratégia Europa



Eibergen, Países Baixos



Líder em soluções de propulsão naval, com mais de 60 anos de experiência



Referência em motores para ambientes de alto risco, como energia e Óleo & Gás



Milão, Itália

Impacto nos Negócios

Complemento à WEG em Portugal em motores à prova de explosão

Expansão geográfica e fortalecimento da presença na Europa

Reforça a atuação da WEG nos segmentos Naval e Área Classificada

Portfólio complementar

Alavanca a rede de distribuição existente, maximizando o alcance e a penetração de mercado



Verticalização WEG e Marathon



Fábrica de fios



Fundição

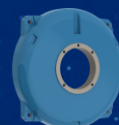

Usinagem de Fundidos



Ferramentaria

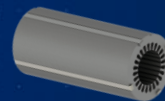

Estamparia

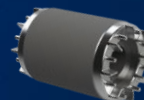

Injeção de Alumínio

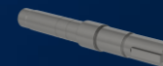

Usinagem de Eixos

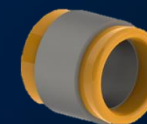

Bobinagem



Montagem



Testes

WEG



Marathon



WEG
DAY
2024

Produtos Marathon



rotor
WEG Group



NAVAL

cemp
WEG Group



**À PROVA DE
EXPLOÇÃO**

marathon



IEEE 841



FIRE PUMP

WEG
DAY
2024

Produtos Foco na Competitividade



Alta Tecnologia e Sustentabilidade

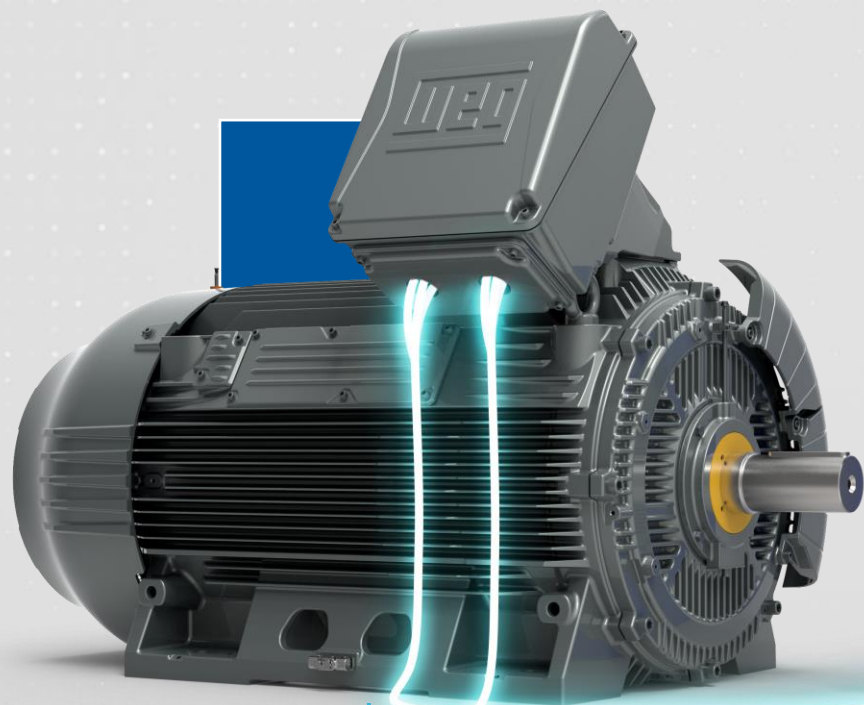

W23 Sync+Ultra



CFW 900

IEC IE5 e IE6

Carcaça IEC 80 a 450

0,75kW até 1250 kW

Motores Síncronos Benchmarking

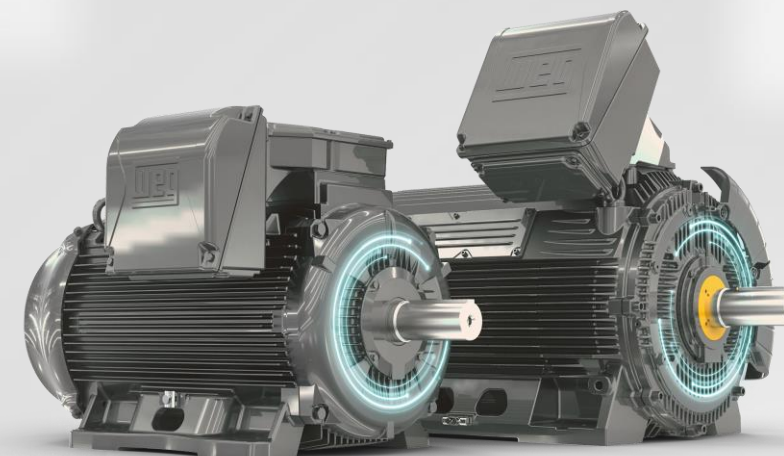
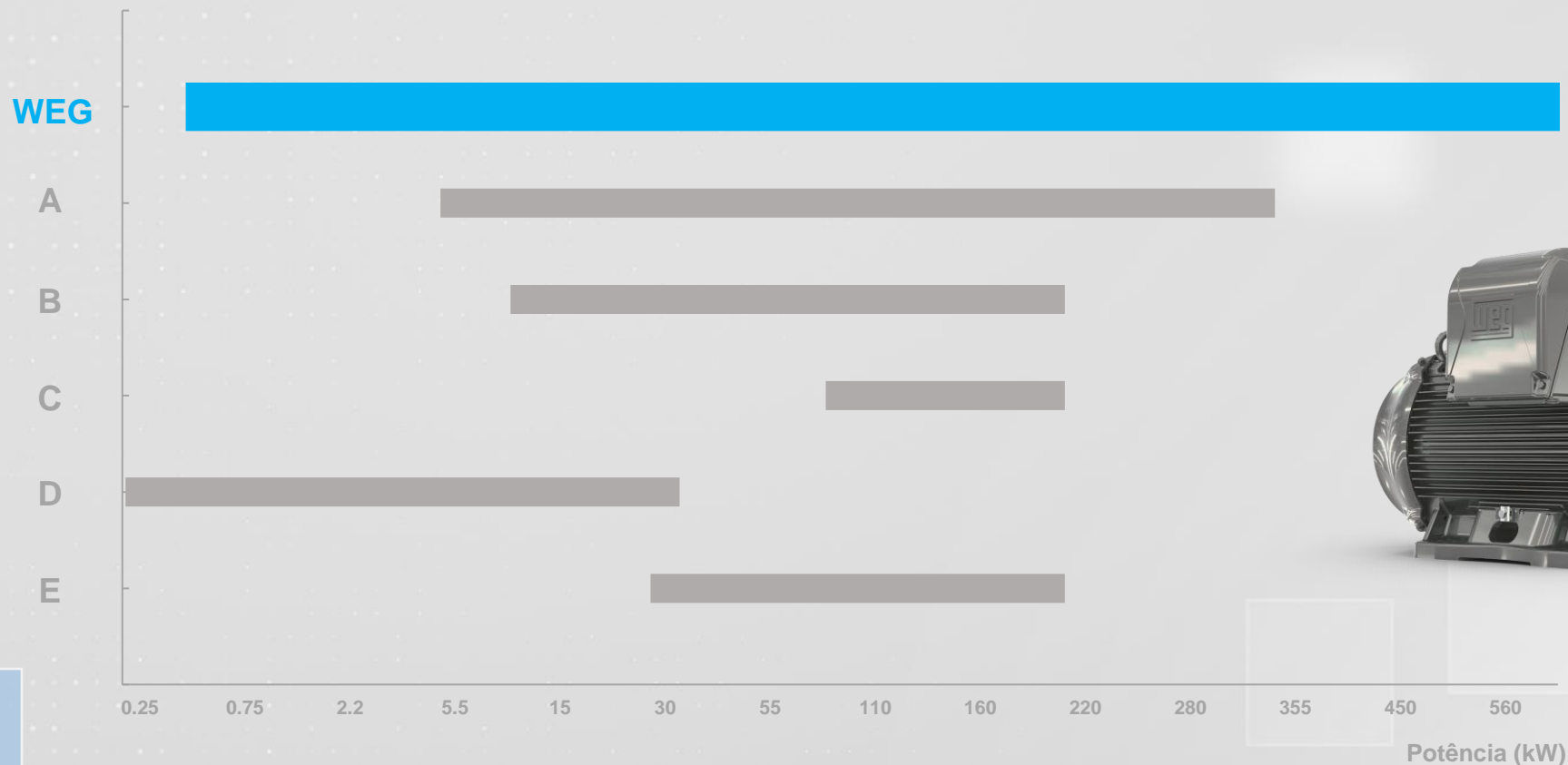

Comparativo de motores **W23 SYNC+** 4 polos com equivalentes dos principais concorrentes



Alta Tecnologia e Sustentabilidade



W80 AXgen + CFW 900

Axial Flux Technology



Lançamento internacional em **Outubro de 2024** e no Brasil em **Janeiro de 2025**



Ampliação da Fábrica México



Componentes para Redutores

R\$ 63
milhões
de investimento

2.500 m²
de área
construída

Início das
operações em
2025

WEG
DAY
2024

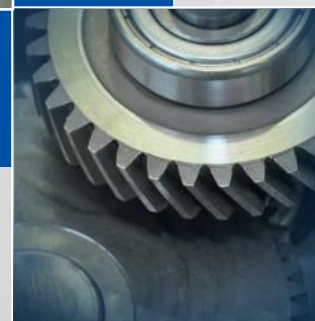

Nova Fábrica de Fios México



Fios Retangulares e Circulares

R\$ 340
milhões
de investimento

24.000 m²
de área
construída

Início das
operações em
2029



WEG
DAY
2024

Ampliação Fábrica de Fios Brasil



Fios Retangulares

R\$ 170
milhões
de investimento

9.500 m²
de área
construída

Início das
operações em
2029

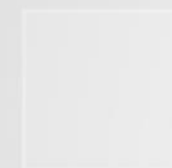
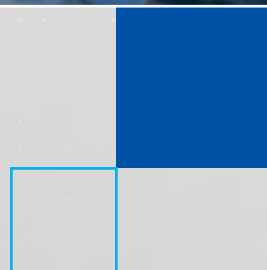
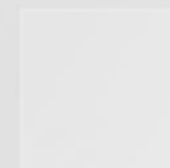

WEG
DAY
2024

Ampliação da Fundição no Brasil



Expansão e Modernização

R\$ 160
milhões
de investimento

6.000 m²
de área
construída

Início das
operações em
2027



WEG
DAY
2024

Principais Mensagens



Presença estratégica **global**

Sinergias **Marathon**

Capacidade de **crescimento**

Inovação e **tecnologia**



WEG DAY

2024

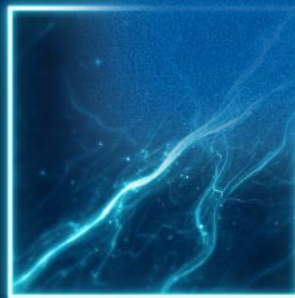

Driving efficiency and sustainability

