

# WEG DAY

2024

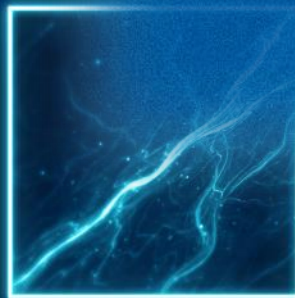

Driving efficiency and sustainability



# Disclaimer



Any forward-looking statements that may be made about future events, at business perspective, at operational and financial projections and goals, and the growth potential of WEG in the future, constitute mere beliefs and expectations of WEG's management, based on information currently available. These statements involve risks and uncertainties and therefore depend on circumstances that may or may not occur. Investors should understand that general economic, industrial, and other operating conditions may affect WEG's future performance and lead to results that differ from those expressed in such forward-looking state.

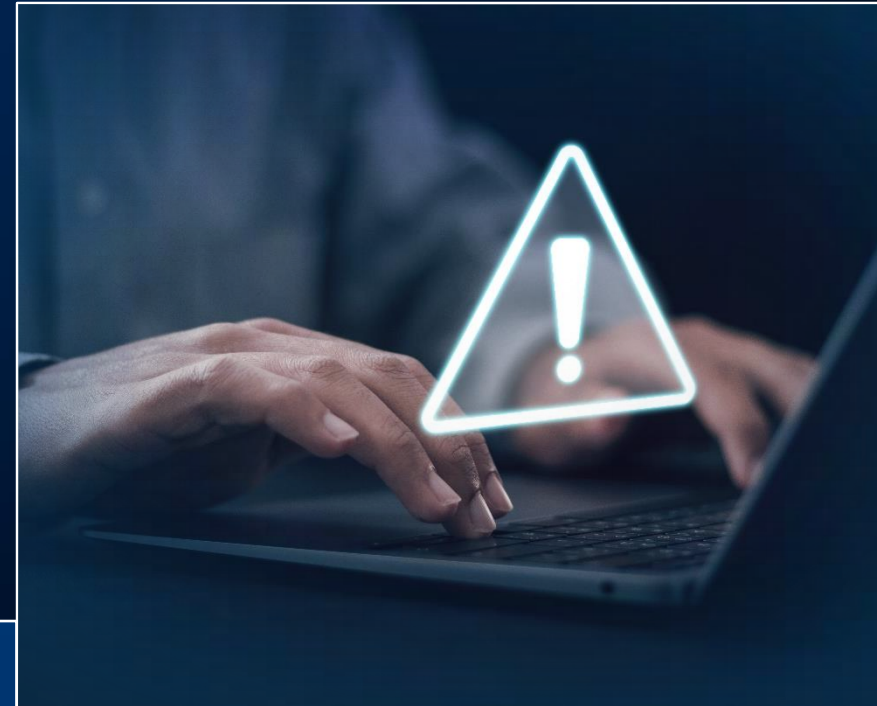

**WEG**  
**DAY**  
2024

# Schedule

Online Broadcast

Simultaneous Translation



**JOÃO PAULO  
GUALBERTO DA SILVA**  
Managing Director  
WEG Energy



**ANDRÉ LUÍS  
RODRIGUES**  
CFO



**RODRIGO FUMO  
FERNANDES**  
Managing Director  
WEG Industrial Motors



**ALBERTO  
KUBA**  
CEO

**9:00 AM** Opening (broadcast start time)

**9:10 AM** Industrial motors strategy

**9:35 AM** Alternators strategy

**10:00 AM** Q&A

**10:20 AM** *Coffee break*

**10:50 AM** Financial update

**11:10 AM** Strategic update

**11:40 AM** Q&A

**WEG  
DAY**  
2024

# Strategy Industrial Motors

**RODRIGO FUMO FERNANDES**

Managing Director  
WEG Industrial Motors



**WEG**  
**DAY**  
2024

# WEG Industrial Motors



 + de **13,000** employees worldwide

 + de **10 mil** motors produced per day

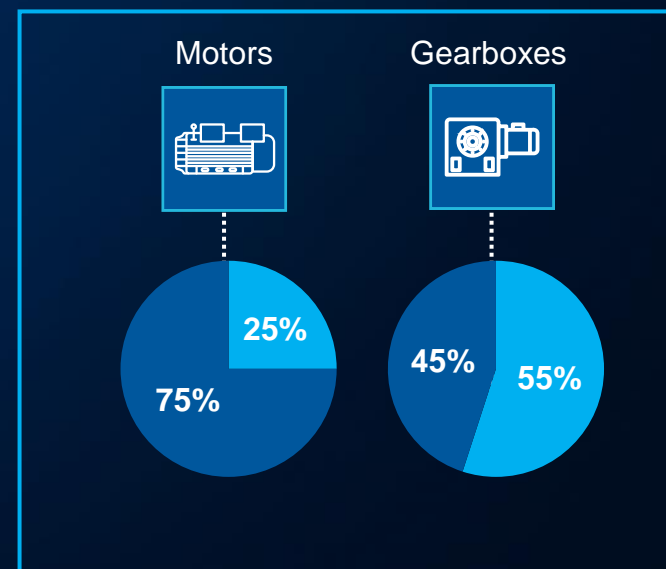

**75%**  
sales in **2023**  
were electric motors of  
**high efficiency**

## Distribution of Global Revenue



+ de  
**R\$ 710** millions  
in investments in 2023

+ de  
**500,000** m<sup>2</sup>  
of built area

 Brazil  
 External Market

**WEG**  
**DAY**  
2024

# Footprint



# Market Share



## Industrial Motors Low Voltage WEG + Marathon\*: 15%

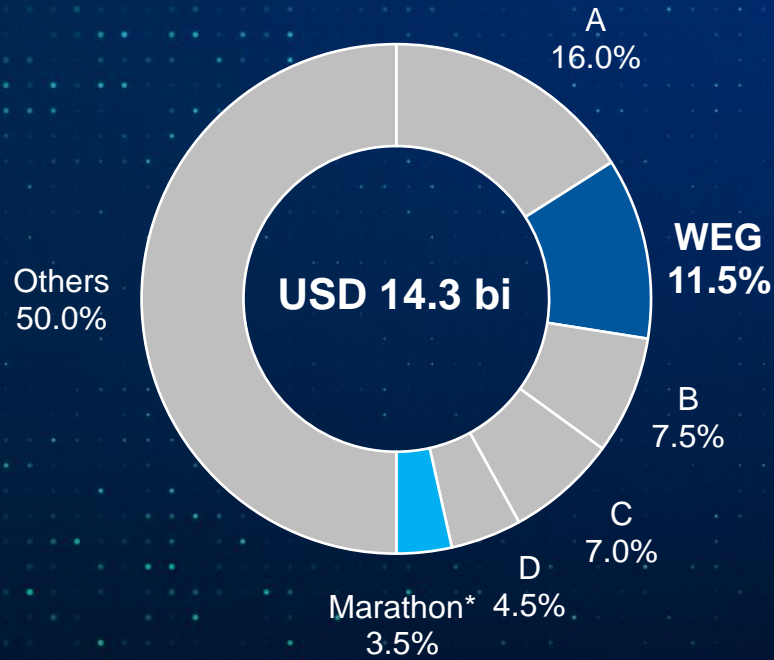

## Market share growth

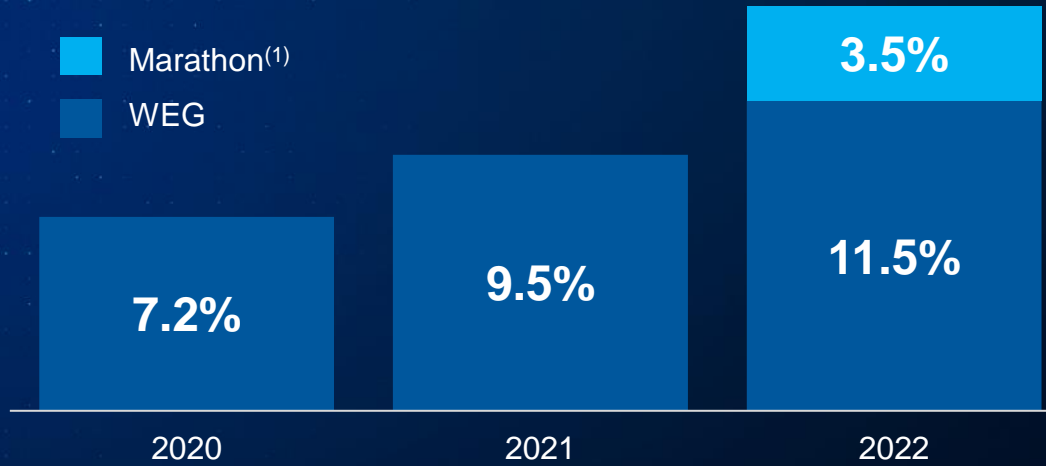

### Americas



### EMEA

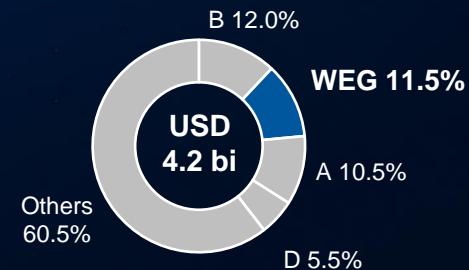

### Asia Pacific

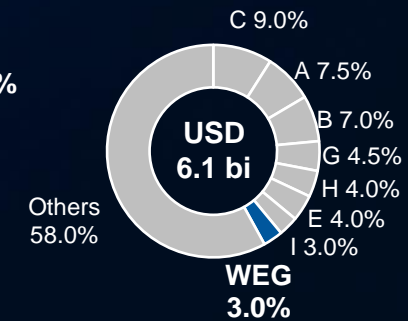

Source: Omdia 2023 – LV Motors  
(1) Considers brands Marathon, Cemp and Rotor



# Marathon Integration



---

**115 participants**

---

**3 days**  
event in  
Jaraguá do Sul

---

**21 presentations**

---

**12 hours**  
of factory visits



**WEG**  
**DAY**  
2024



# Marathon Integration



**Day 01**  
**Closing Date**  
May 01, 2024

- WEG and Marathon merge
- 2,500 employees
- Integration begins

**Integration Meeting**  
June 17, 2024

- Marathon Executives at Jaraguá do Sul
- WEG Business Structure
- Governance, Culture, Mission, and Vision
- Integration strategies

**Marathon Integration Group**  
July 03, 2024

- Marathon and WEG Executives
- Multidisciplinary group
- Permanent forum
- Identify synergies
- Operational improvements
- Gain in competitiveness



# Strategy North America



## Century-old Brand in America

Strong presence in the automotive, metallurgical, pulp and paper, and Commercial HVAC<sup>(1)</sup> sectors

## Synergies and Opportunities

- Four new factories
- Drives WEG's Motion Drive strategy
- Providing complete solutions with variable frequency drivers
- Strengthens WEG's presence in important segments
- Scale gains in the synergy from Marathon Monterrey and WEG Mexico

Wausau, US



Monterrey, Mexico



(1) Heating, Ventilating and Air Conditioning

# Strategy China



Recognized brand  
in operation  
since **1958**

Low voltage IEC/NEMA  
and medium voltage IEC  
motors

## Synergies and Opportunities

- Inclusion of WEG drivers and gearboxes in Marathon's supply packages
- Production of motors for export
- Knowledge and experience of the local Marathon team
- Gains in synergy between Marathon and WEG China



Wuxi, **China**

**WEG**  
**DAY**  
2024

# Strategy India



Ahmedabad, India

## Synergies and Opportunities

- Two new plants, in Kolkata and Ahmedabad
- Greater proximity to India's major industrial clusters
- Participation in important segments such as Flame Proof, Smoke Extraction, Crane Duty, Slipring, Brake Motor
- Expansion of the network of Resellers and Service Centers



Kolkata, India

**WEG**  
**DAY**  
2024

# Strategy Europe



Eibergen, **Netherlands**



Leader in marine propulsion solutions, with more than 60 years of experience



Reference in motors for high-risk environments, such as energy and Oil & Gas



Milan, **Italy**

## Business Impact

Complement to WEG in Portugal in explosion-proof motors

Geographical expansion and strengthening of presence in Europe

Reinforces WEG's performance in the Naval and Hazardous Area

Complementary portfolio

Leverages existing distribution network, maximizing reach and market penetration



# Vertical Integration WEG & Marathon

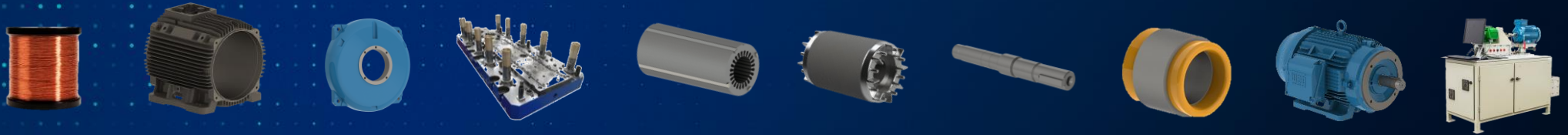

Wire Factory

Casting

Cast Iron  
Machining

Tooling

Stamping

Aluminum  
Die casting

Shaft  
Machining

Winding

Assembly

Testing

WEG

Marathon



WEG  
DAY  
2024

# Marathon Products



**rotor**  
WEG Group



MARINE

**cemp**  
WEG Group



EXPLOSION  
PROOF

**marathon**



IEEE 841



FIRE PUMP



# Products Focus on Competitiveness





# High Technology and Sustainability

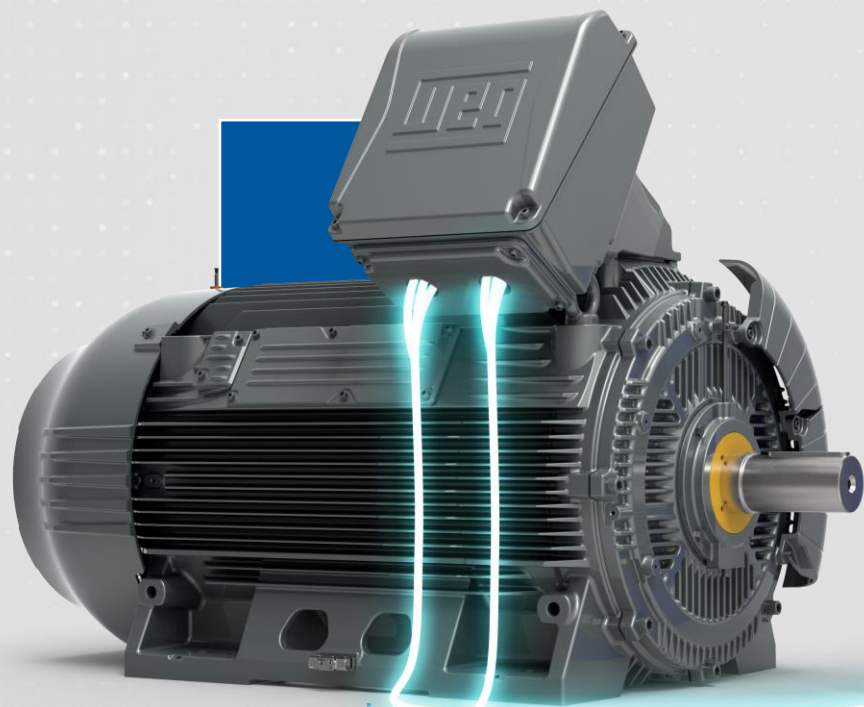

W23 Sync+Ultra



CFW 900

IEC IE5 and IE6

Frame IEC 80 to 450

0.75kW up to 1250 kW



# Synchronous Motors Benchmarking

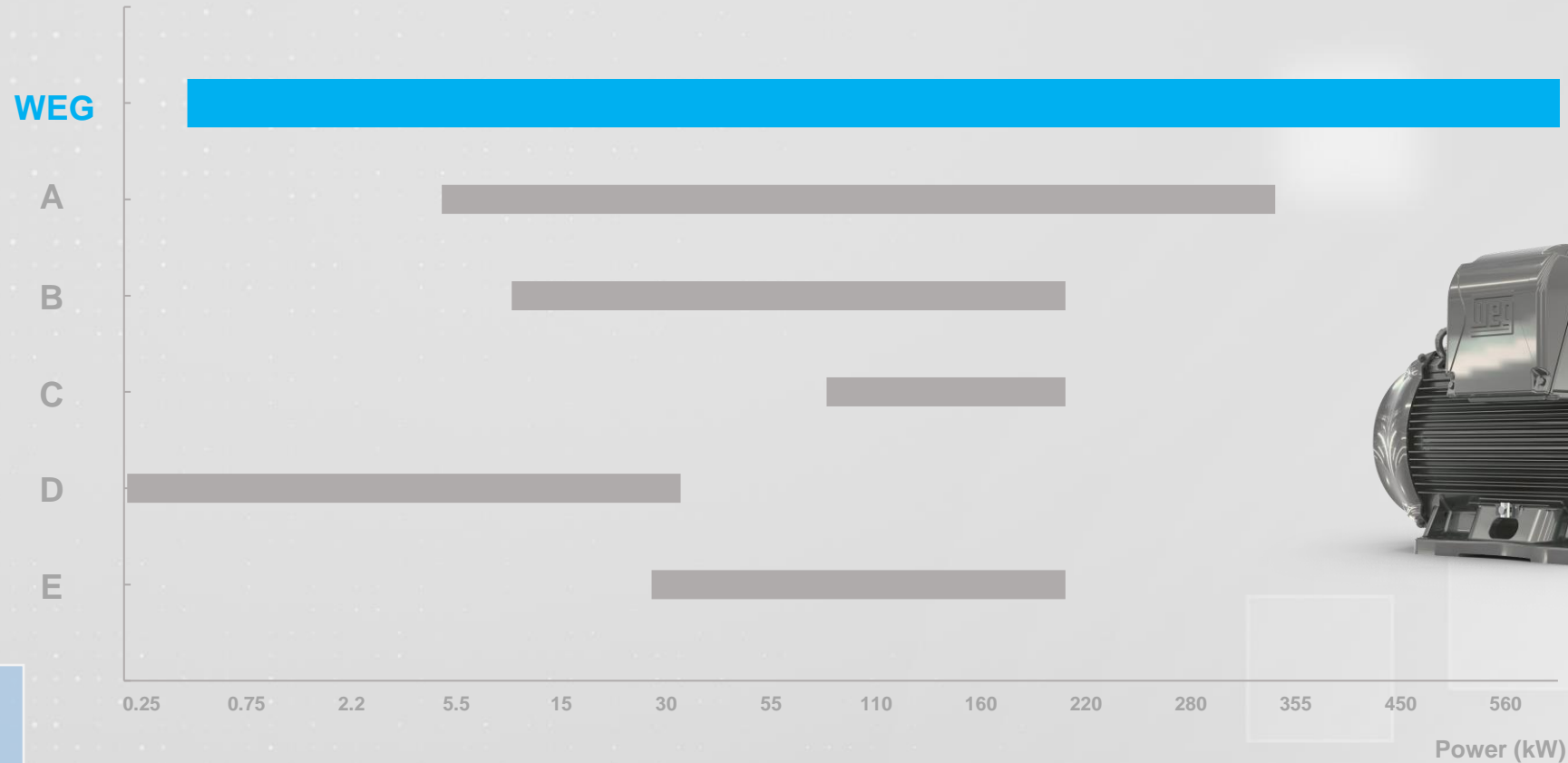

W23 SYNC+ 4-pole motor comparison with main competitor's equivalent



# High Technology and Sustainability



## W80 AXgen + CFW 900

Axial Flux Technology



International release in **October 2024** and for Brazil in **January 2025**



# Factory Expansion Mexico



## Components for Gearboxes

R\$ 63  
millions  
investment

2,500 m<sup>2</sup>  
built area

Start of  
operations in  
2025

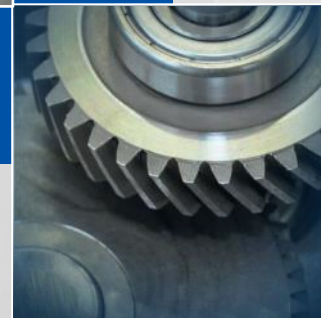

# New Wire Factory Mexico



## Rectangular and Circular Wires

R\$ 340  
millions  
investment

24,000 m<sup>2</sup>  
built area

Start of  
operations in  
2029



**WEG**  
**DAY**  
2024

# Wire Factory Expansion Brazil



## Rectangular Wires

R\$ 170  
millions  
investment

9,500 m<sup>2</sup>  
built area

Start of  
operations in  
2029

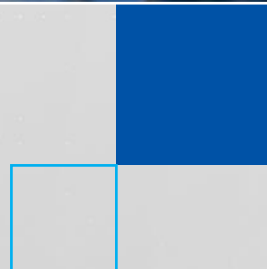
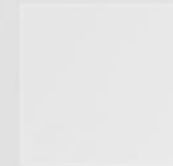

**WEG**  
**DAY**  
2024

# Foundry Expansion Brazil



## Expansion and modernization

R\$ 160  
millions  
investment

6,000 m<sup>2</sup>  
built area

Start of  
operations in  
2027



**WEG**  
**DAY**  
2024

# Key Messages



**Global Strategic presence**

**Marathon Synergy**

**Growth capacity**

**Innovation and technology**





# WEG DAY

2024

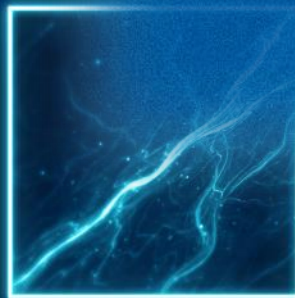

Driving efficiency and sustainability



# Alternators Strategy

**JOÃO PAULO  
GUALBERTO DA SILVA**  
Managing Director  
WEG Energy



**WEG**  
**DAY**  
2024

# WEG Energy



**Complete solutions**

For renewable energy generation

**Wide Service Network**

**Marathon**  
+3 factories



+  
**5,100**  
employees worldwide



+  
**30,000**  
+1,000 HP medium voltage motors delivered

**9**

factories

in

**7**

countries

in

**4**

continents

Distributors in **+ 120** countries



+  
**132 GW**

Installed in power generation



+  
**5,000**

Turbo and hydro generators produced



+  
**1,1 GW**

Installed in wind turbines



+  
**255,000**

Synchronous alternators produced



+  
**1,300**

Steam turbines produced for thermal generation by biomass

**WEG**  
**DAY**  
2024

# Footprint



# Market Share



## Alternators

WEG + Marathon: 9.1%

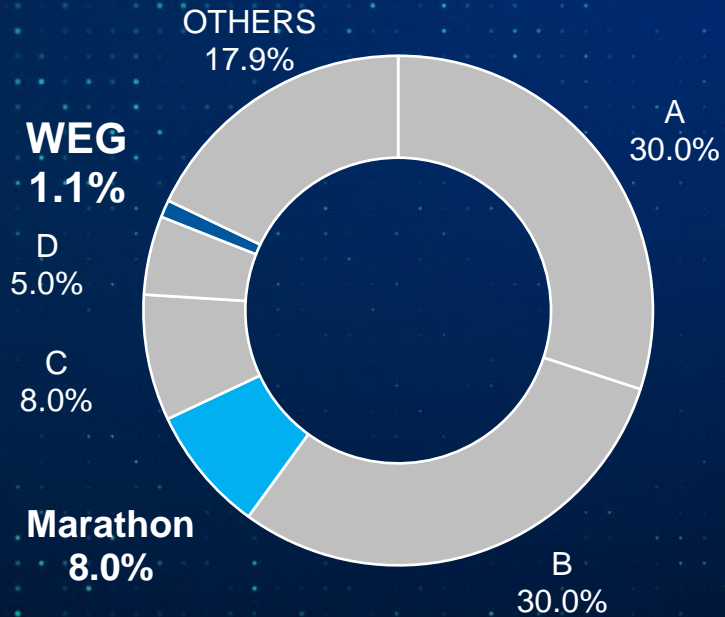

## Brazil

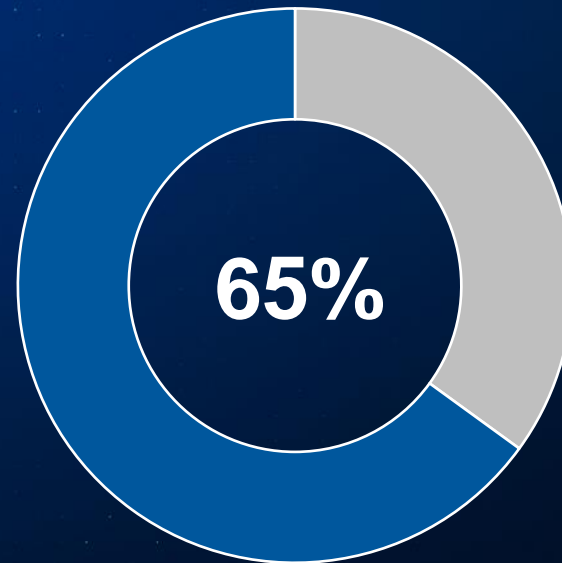

## North America

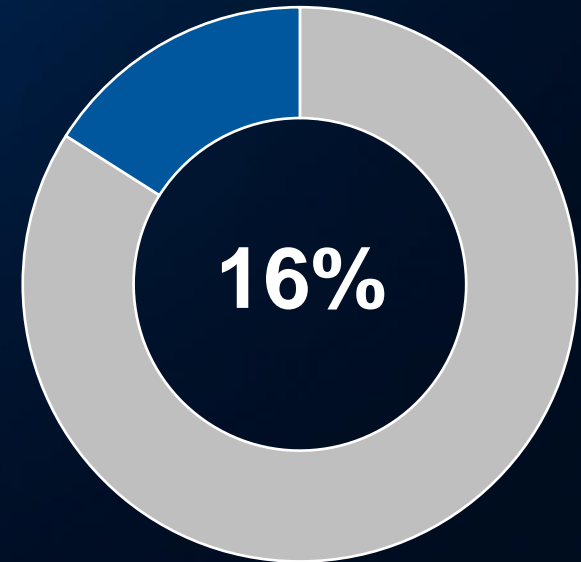

Source: Omdia



# Timeline Alternators

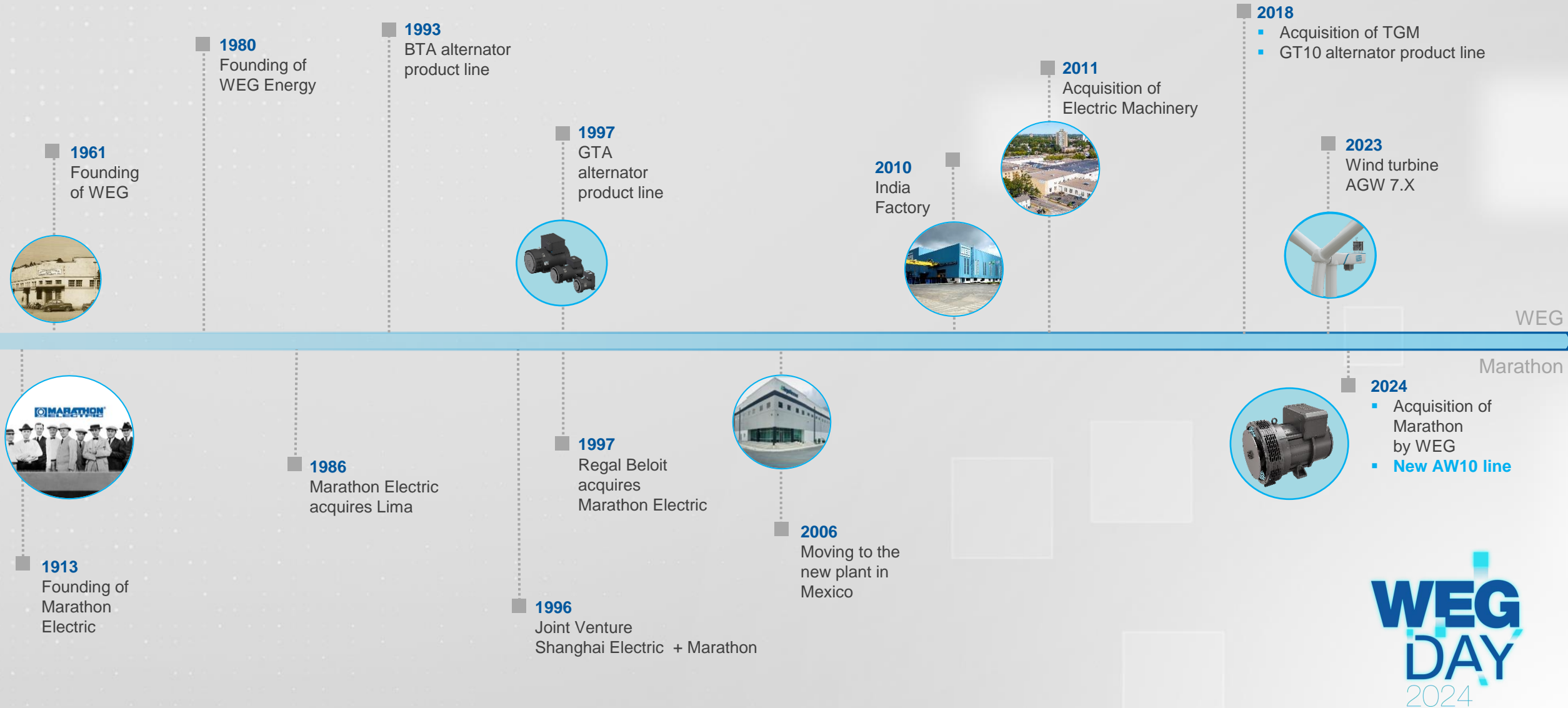

# Global Strategy Alternators



## North America Marathon

Traditional brand with excellent reputation

Regain market share

Dedicated production lines in the US and Mexico

Production and Engineering close to customers

Vertical integration of WEG Mexico as a supplier

Costs and lead times reduction

## South and Central America WEG

Production and Engineering close to customers

Open new markets and local support

Factory dedicated to alternator business

Important logistical gains

Good brand positioning



# Global Strategy Alternators



## China Marathon

JV 55% Marathon and 45% Shanghai Electric  
Production and Engineering close to customers  
Open new markets and local support  
Factory dedicated to the alternator business  
Important logistical gains  
Good brand positioning in the market

## Europe and Middle East Marathon

Traditional brand with an excellent reputation  
Regain customers in the medium term





# Commercial Strategy Alternators



Focus on **partnerships** with the main OEMs in the market

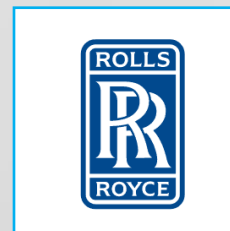

# Integration Strategy



Use WEG's **vertical integration** for production and supply chain improvements

Cast iron from **Mexico** to support the Monterrey and Wausau structure

**Suppliers** of WEG units in **India and China**



**Stamping** production unit in **Mexico**

Production gains with stamped sheets **standardization**



**WEG**  
**DAY**  
2024

# Integration Strategy



Use WEG's **vertical integration** for production and supply chain improvements

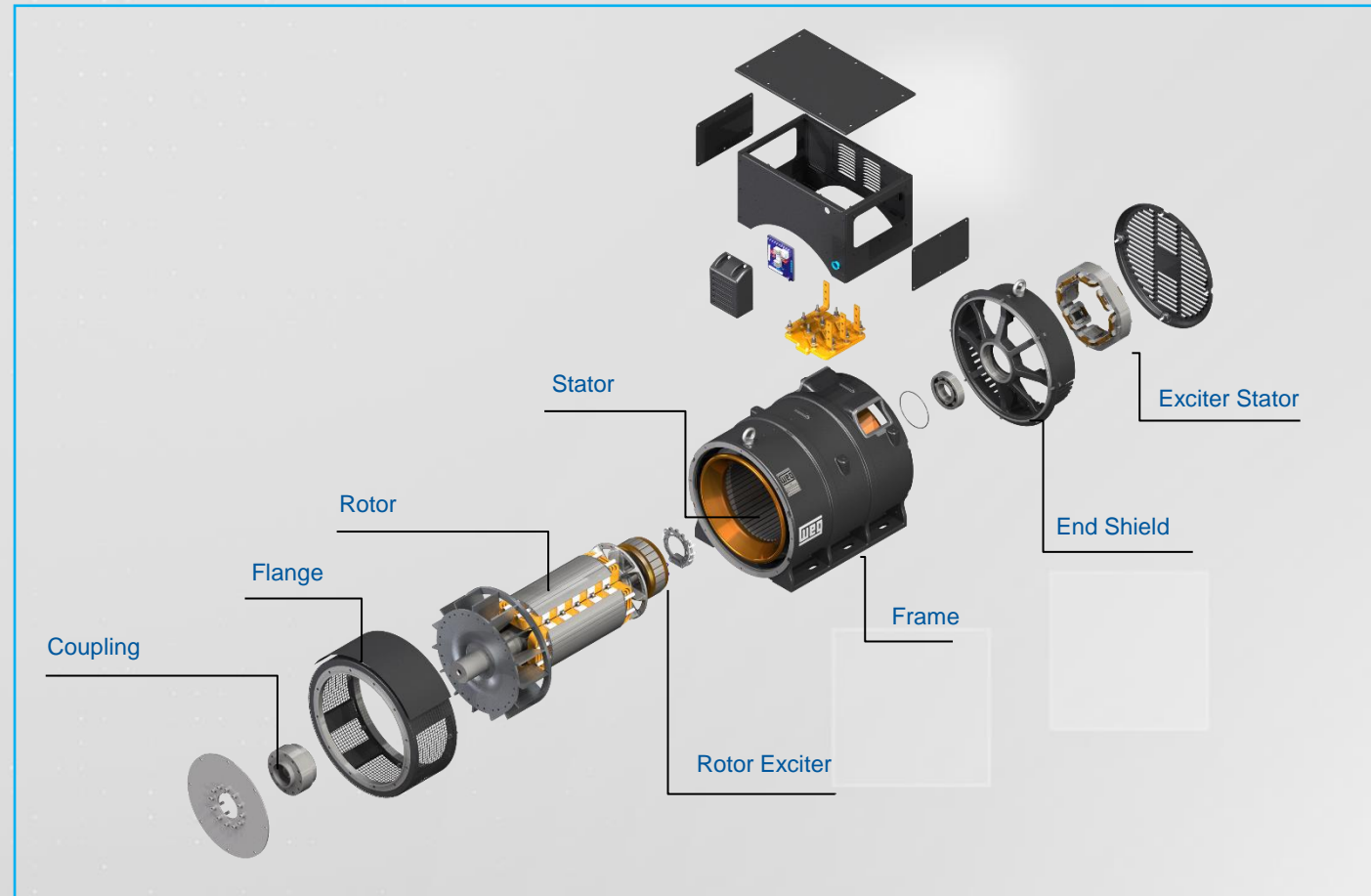

# Alternators Committee



## PRODUCTS

Evaluation of new products and technologies

Pipeline priority validation for new products

## SALES & MARKETING

Product portfolio

Sales Analytics

Trends and market segments

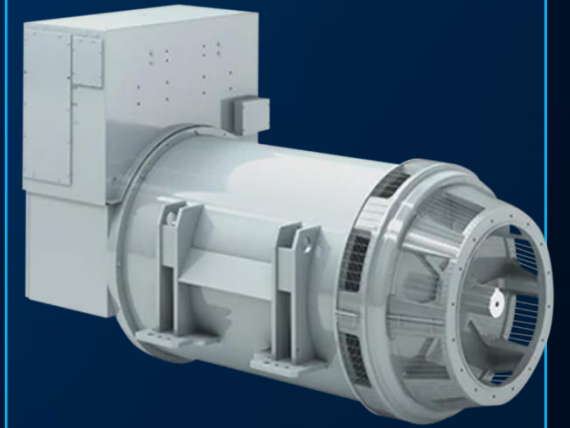

## QUALITY

Product Certification  
Governance

Products, Laboratories and  
Manufacturing Plants

## OTHER INITIATIVES

Competition Mapping

Customer Movements

Best Practices/Tactical Plan  
Promotion



# Global Sales 2023



## Sales Channel

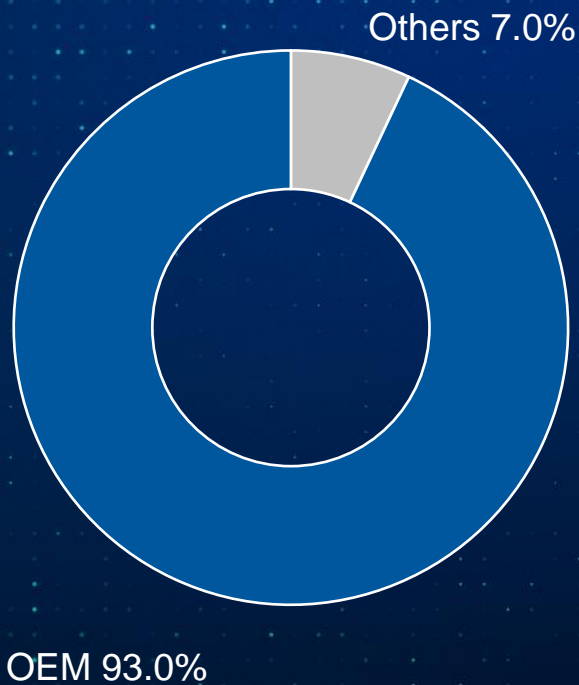

## Product Type

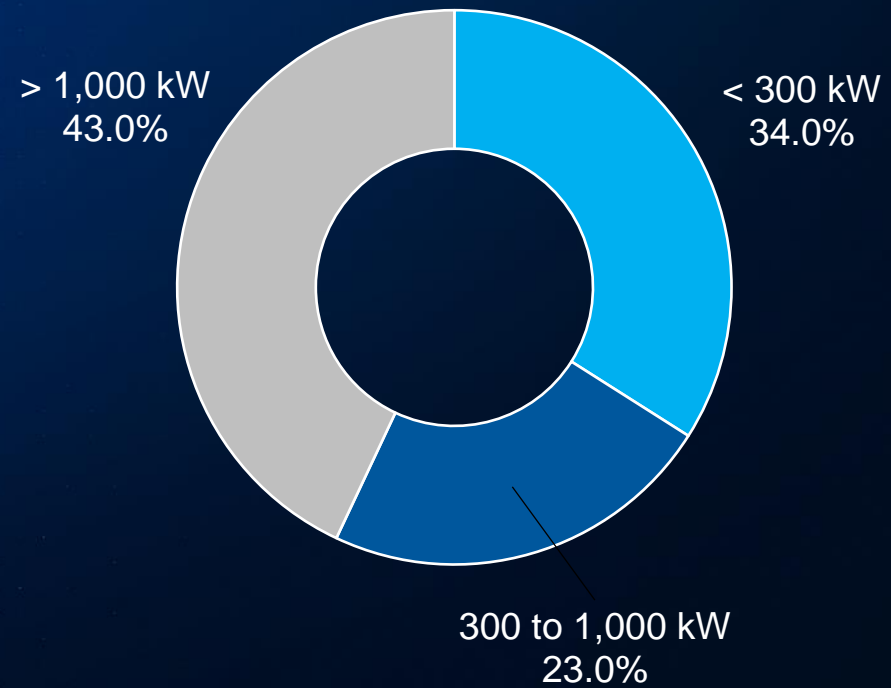

Source: Omdia



# Alternators Business Strategy



Continued use in critical applications such as hospitals, airports, telecommunications

Advancing AI and cloud services increases demand for Data Center applications

Energy consumption grows faster than new sources of generation

More frequent blackouts due to high power usage

EVs<sup>(1)</sup> growth adding demand to an already saturated grid



(1) Electric Vehicles



# Key Messages



**Marathon Business  
Integration**

**Important market  
for WEG Energy**

**Consolidation of  
global presence**

**WEG  
DAY  
2024**

**WEG**  
**DAY**  
2024

# Q&A

Driving efficiency and sustainability





# WEG DAY

2024

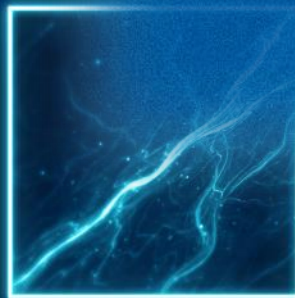

Driving efficiency and sustainability



# Financial Update

**ANDRÉ LUÍS RODRIGUES**  
CFO



**WEG**  
**DAY**  
2024

# WEG at a Glance



+

**45,000**

employees  
worldwide



+

**4,700**

engineers



+

**60,000**

Motors  
produced  
per day

**63**

factories

in

**17**

countries

in

**4**

continents

Distributors in **+ 120 countries**

**59%**

of **2023's** revenue  
came from products launched in  
**the last 5 years**

R\$

**228.3  
Billion**

in market value  
(Sep/2024)

Stock Exchange

**WEGE3 (B3)**

**WEGZY (OTC – ADR Level 1)**

**WEG  
DAY**  
2024

# Performance



Net Operating Revenue **+9.1%**

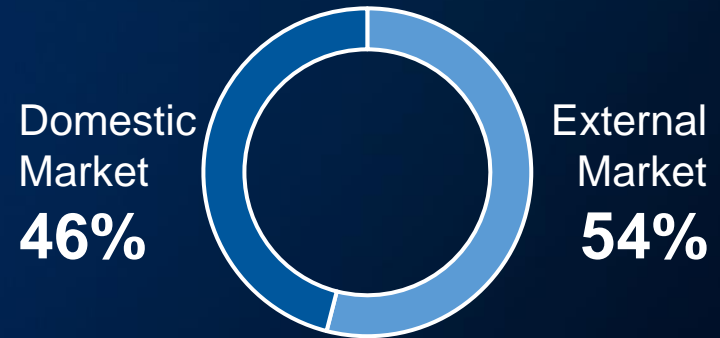

**Industrial Electro-Electronic Equipment (EEI)**

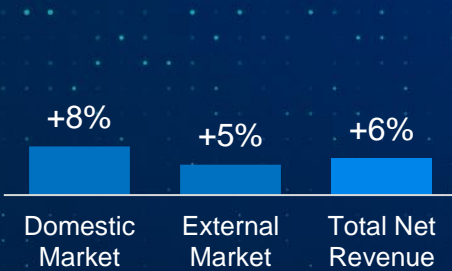

**Energy Generation, Transmission and Distribution (GTD)**

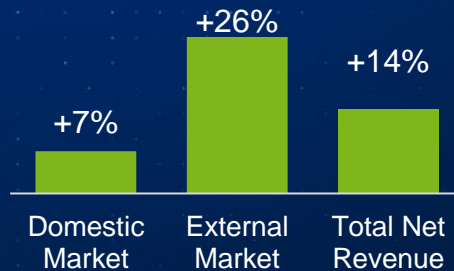

**Commercial and Appliance Motors (MCA)**



**Paints and Varnishes (T&V)**

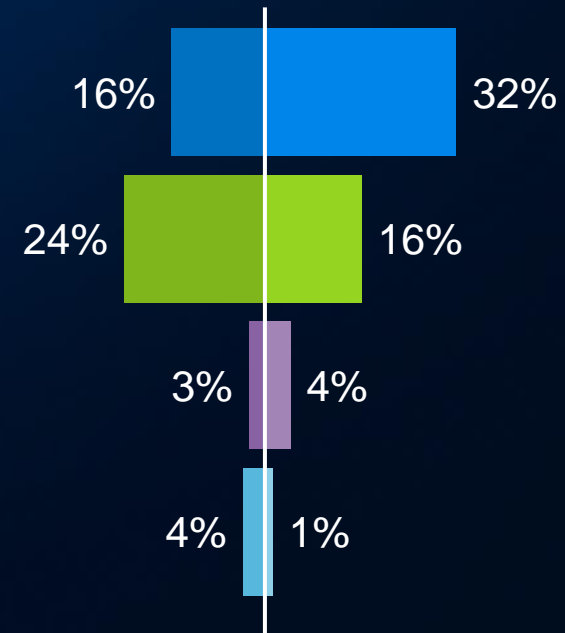
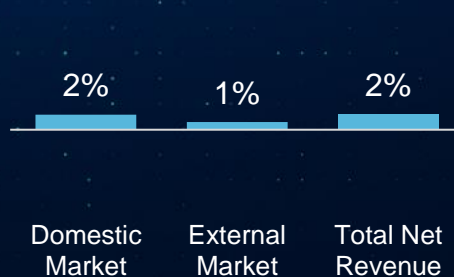

**Δ% 06M24 / 06M23**



# Operating Results

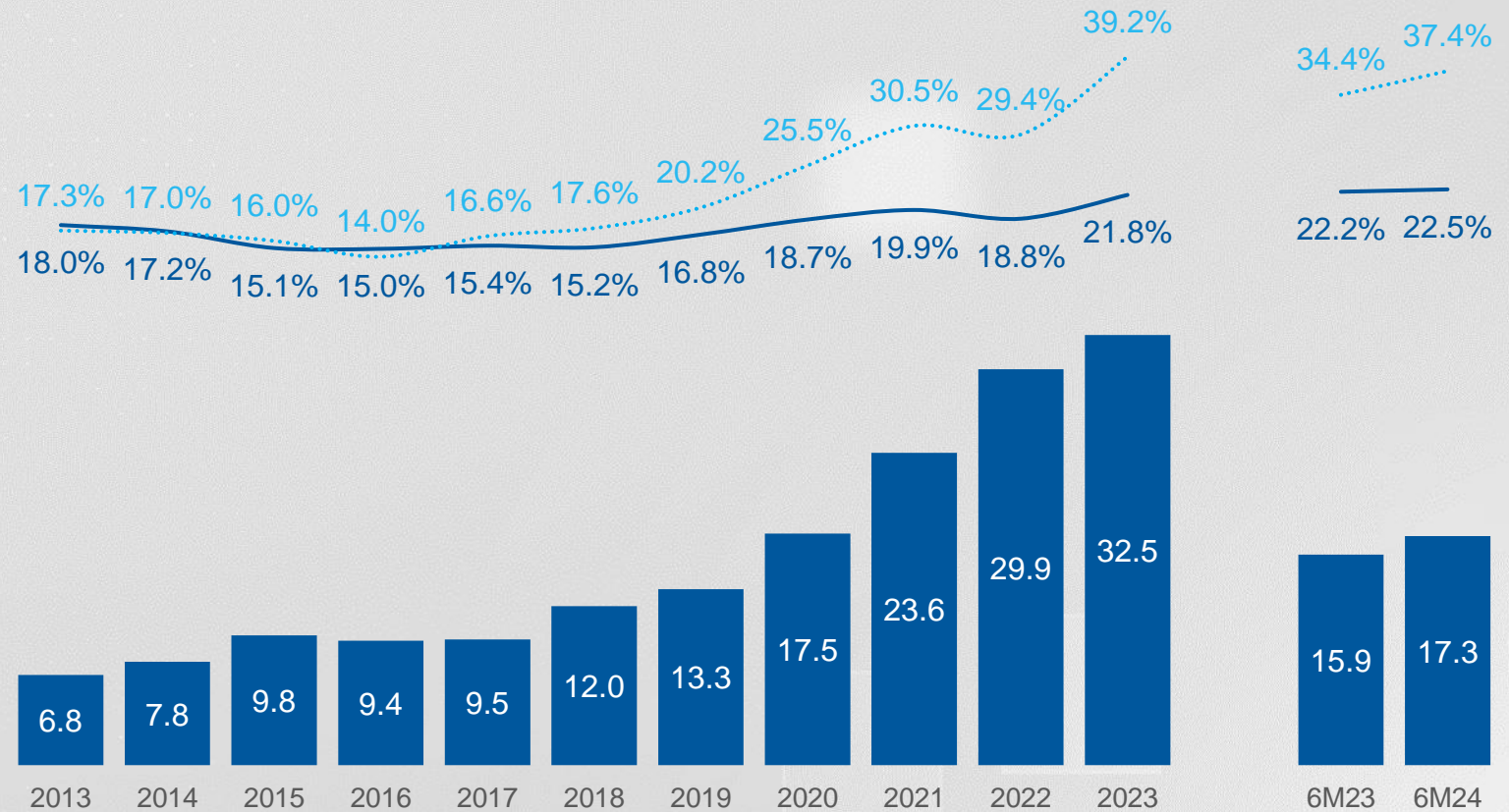

■ Net Revenue (R\$ Billions)
 — Margem EBITDA
 ⋯ ROIC



# Cash Flow Conversion



Considered **EBITDA** of the last 12 months in relation to **Operating Cash Flow**

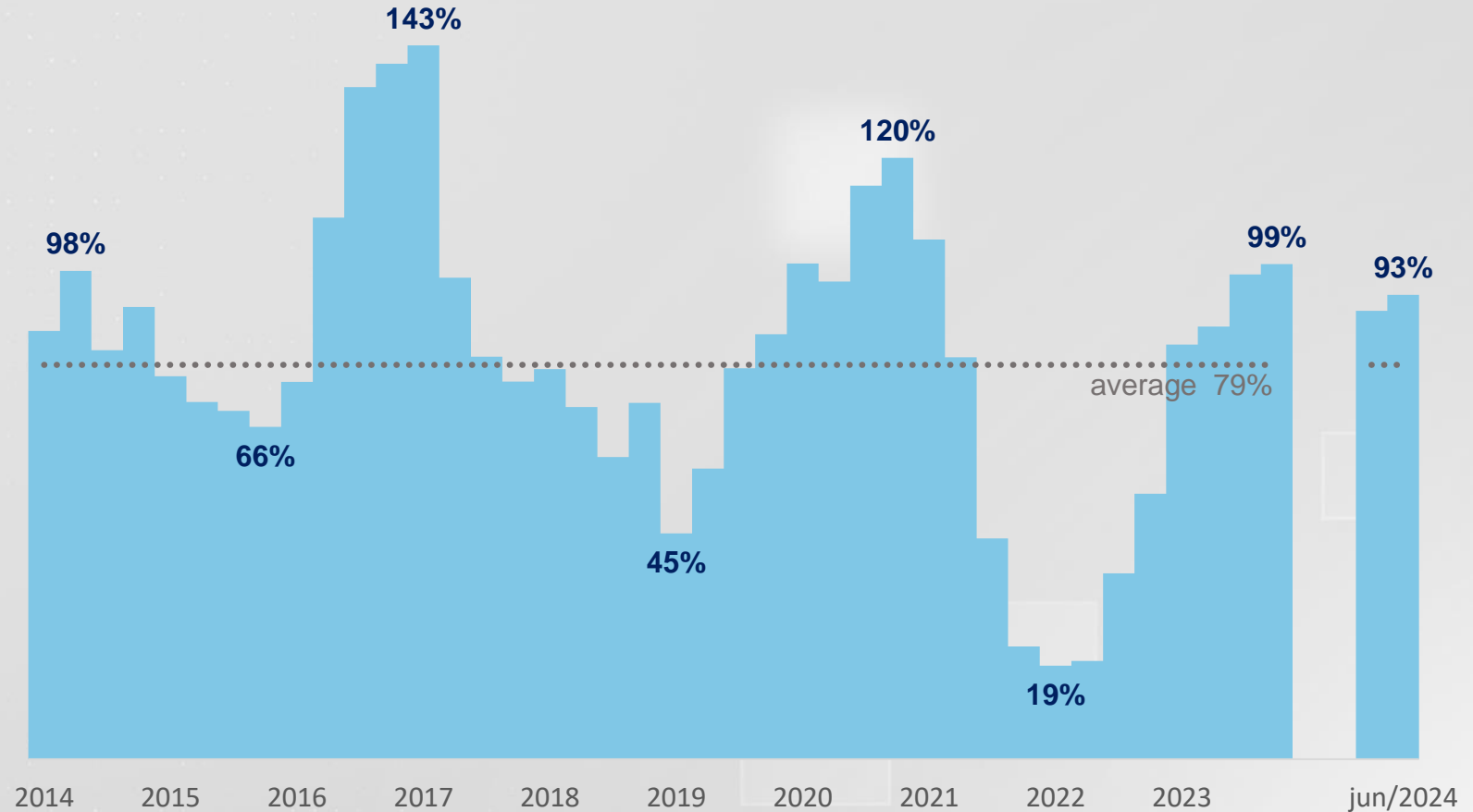

Net cash position of **R\$ 3.0 billion** in June 2024



# Dividend Flow

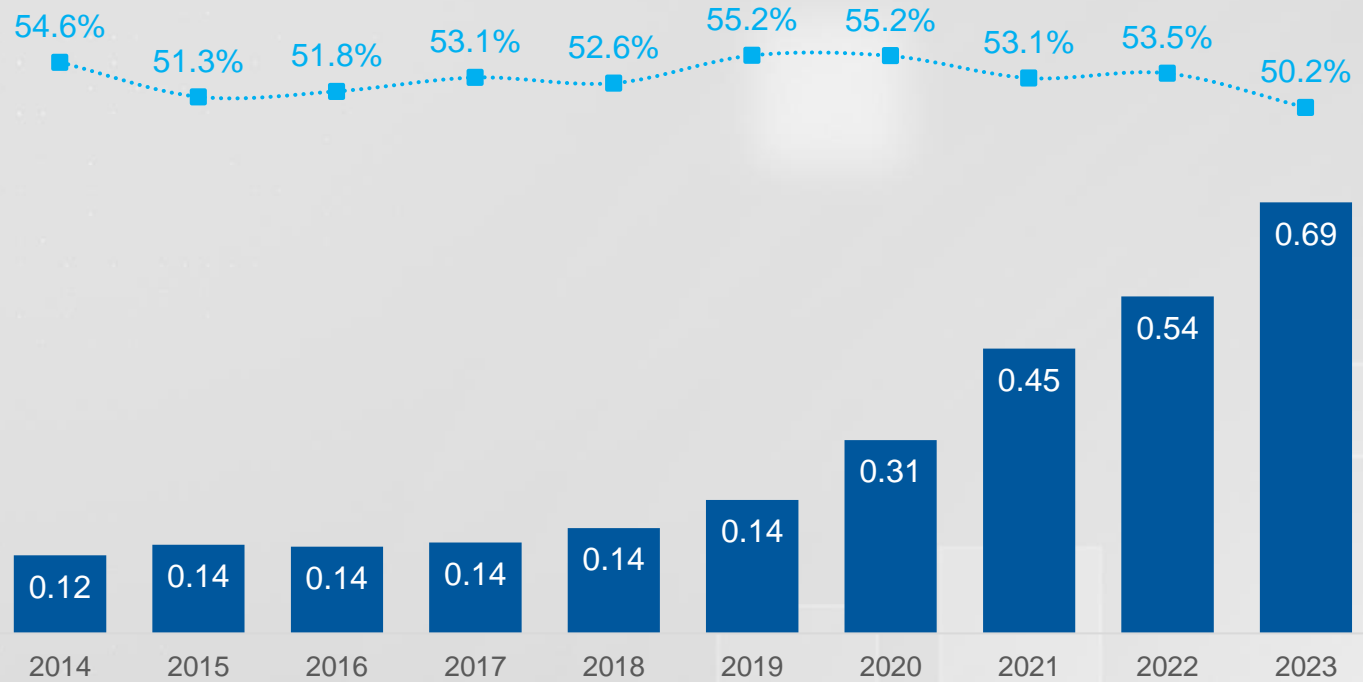

Dividends per share (R\$)



Pay-out (%)



# Marathon Integration



**Administrative areas** integration

Consolidation of **activities** and process **standardization**

Implementation of the **WEG Business Services (WBS)** in the operations



**WEG**  
**DAY**  
2024



# Integração Marathon



Evaluation and  
deployment of  
**Information  
Security** tools

Installation  
of a new  
**Data Center**

Separation and  
**System  
Integration**

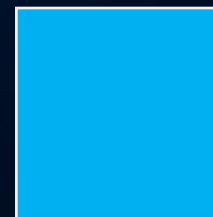
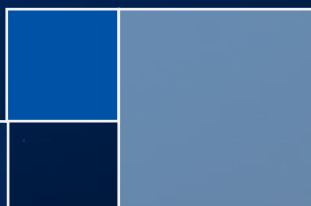
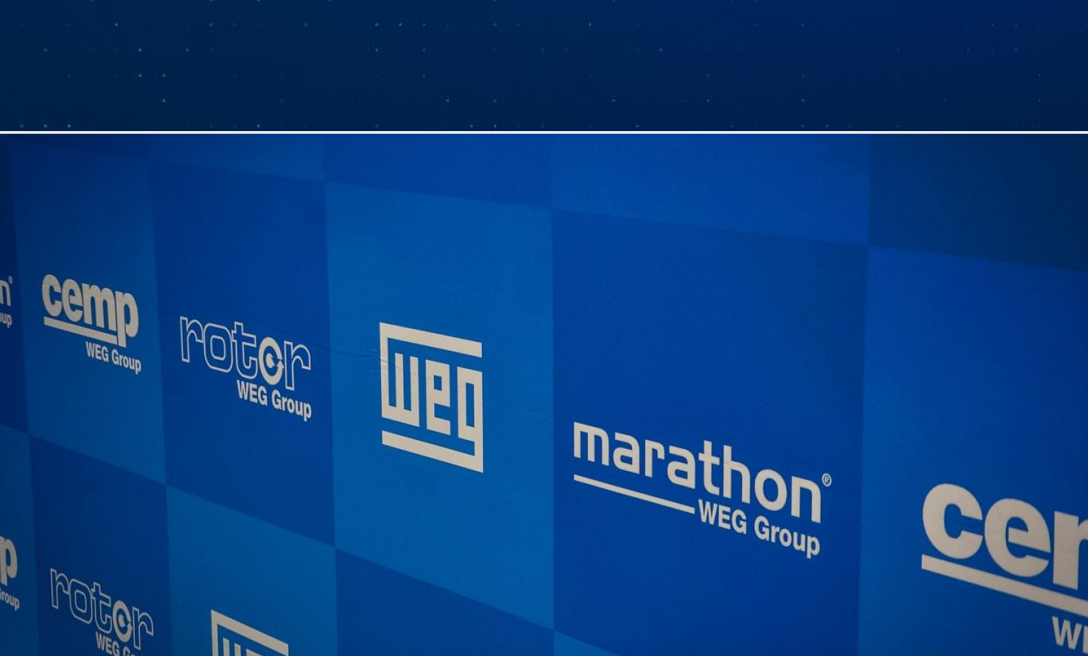

**WEG  
DAY**  
2024

# Investments

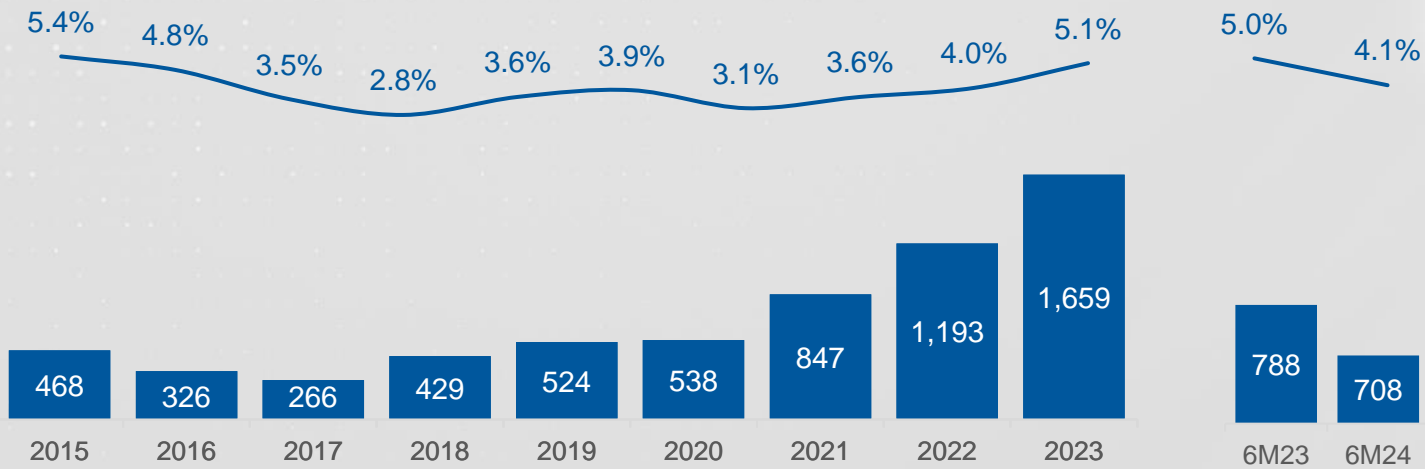

Investments



# New Paint Factory Mexico



## Industrial Liquid Paints

R\$ 100  
millions  
investment

5,300 m<sup>2</sup>  
built area

Start of  
operations in  
2026



**WEG**  
**DAY**  
2024

# Factory Expansion **Betim**

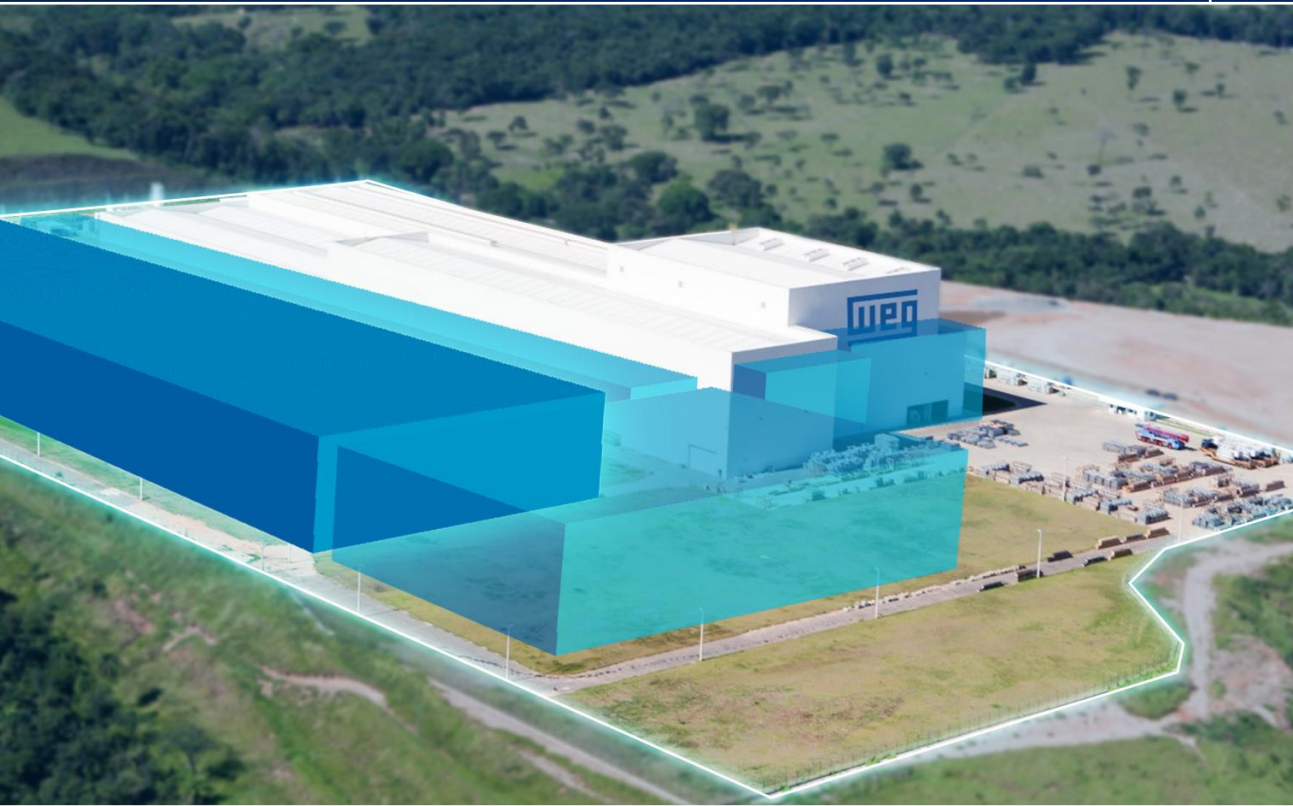

## Power **Transformers**

**R\$ 370**  
millions  
investment

**75,000 m<sup>2</sup>**  
built area

Start of  
operations in  
**2026**

**WEG**  
**DAY**  
2024

# Factory Expansion Gravataí



Transformers up to 230 kV

R\$ 128  
millions  
investment

7,300 m<sup>2</sup>  
built area

Start of  
operations in  
2026



**WEG**  
**DAY**  
2024

# Key Messages



Consistent **Cash Generation**

Improvements as **Integration** progresses

Healthy **EBITDA Margin** and **ROIC**



# WEG DAY

2024

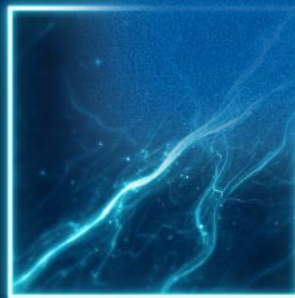

Driving efficiency and sustainability



# Strategy Update

**ALBERTO KUBA**  
CEO



**WEG**  
**DAY**  
2024



# Transition of Command



## Acknowledgment

- Board of Directors
- Harry Schmelzer Jr.
- Executive Board
- Employees

## Transition process



# Still Challenging Scenario on Main Markets



## US

- Manufacturing PMI Falling
- Moderate Industrial Production Growth
- Stability in durable goods prices
- Persistent challenges in the labor market

## Europe

- Purchasing Managers' Manufacturing Index (PMI) down since 2023
- Economic activity slowing down
- Challenges in the manufacturing sector
- Consumption still weak

## China

- Decline in Foreign Direct Investment (FDI)
- Decline in capital goods output



# We Move Forward on Several Fronts



**Increase** international participation with the **Motion Drive** strategy

**Growth in sales** of projects for **Medium Voltage (MV) Motors and Drives**

Recovery in sales of **Commercial & Appliance Motors**

Expansion and strengthening of the **Transmission & Distribution (T&D) business**

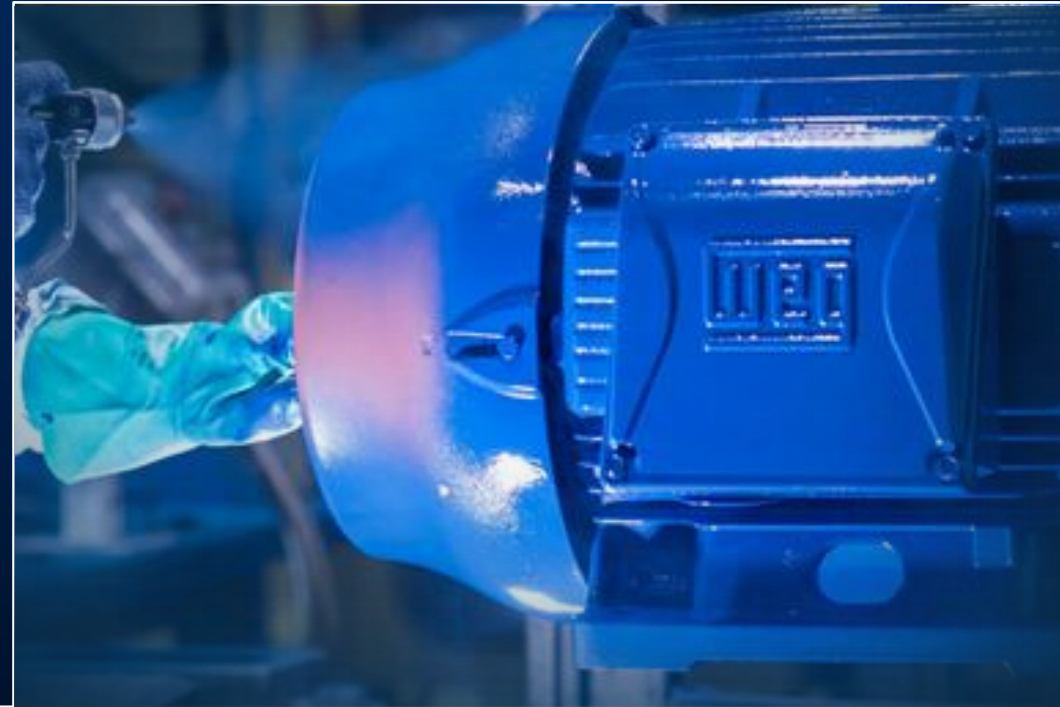

**WEG**  
**DAY**  
2024

# Favorable Winds to Business



## Investments for Energy Transition

Energy Efficiency  
Operational Efficiency

Renewable Energies  
Electric Mobility

## Growth in the use of Generative AI

Data Center Expansion  
Increased energy consumption

Network availability  
Grid reliability



# Energy Transition



**Global investment in technologies** for energy transition has reached a record **\$1.7 trillion in 2023** <sup>(1)</sup>

**To achieve the goals of the Paris Agreement**, the average annual Investment needs to almost triple, reaching **\$4.8 trillion** between 2024 and 2030 <sup>(1)</sup>

Estimates that the **Transformer market will grow 5% p.a. by 2030**, driven by renewable generation, electrification and grid modernization <sup>(2)</sup>

The **Electrified Transportation Sector** was the **biggest driver of investments** in energy transition in 2023 with US\$ 634 billion <sup>(3)</sup>



(1) BloombergNEF Energy Transition Investment Trends 2024

(2) Mckinsey/WEG 2024

(3) Article: CNBC Spencer Kimball Aug 2024

# Traditional Businesses Strategy



## Motion Drives



## MV Motors & Drives

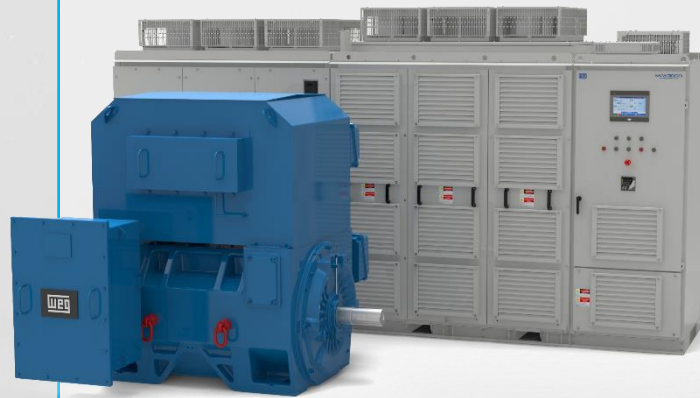

## Transmission & Distribution

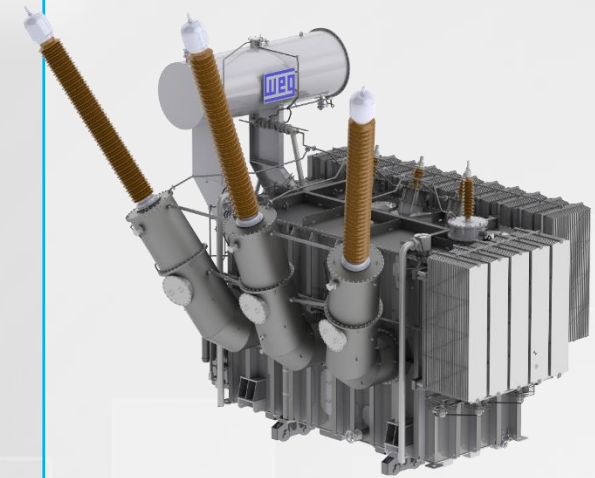

# Commercial Structure



Commercial presence in **41** countries





Distributors in more than **120** countries



# Industrial Footprint Motion Drive



29 factories in 13 countries

-  Low Voltage Industrial Motors WEG
-  Low Voltage Industrial Motors Marathon
-  Low Voltage Drives
-  Gearboxes and Geared Motors





# Industrial Footprint Medium Voltage



11 factories in 6 countries



Medium Voltage Industrial Motors



Medium Voltage Drives

WEG  
DAY  
2024

# Industrial Footprint T&D

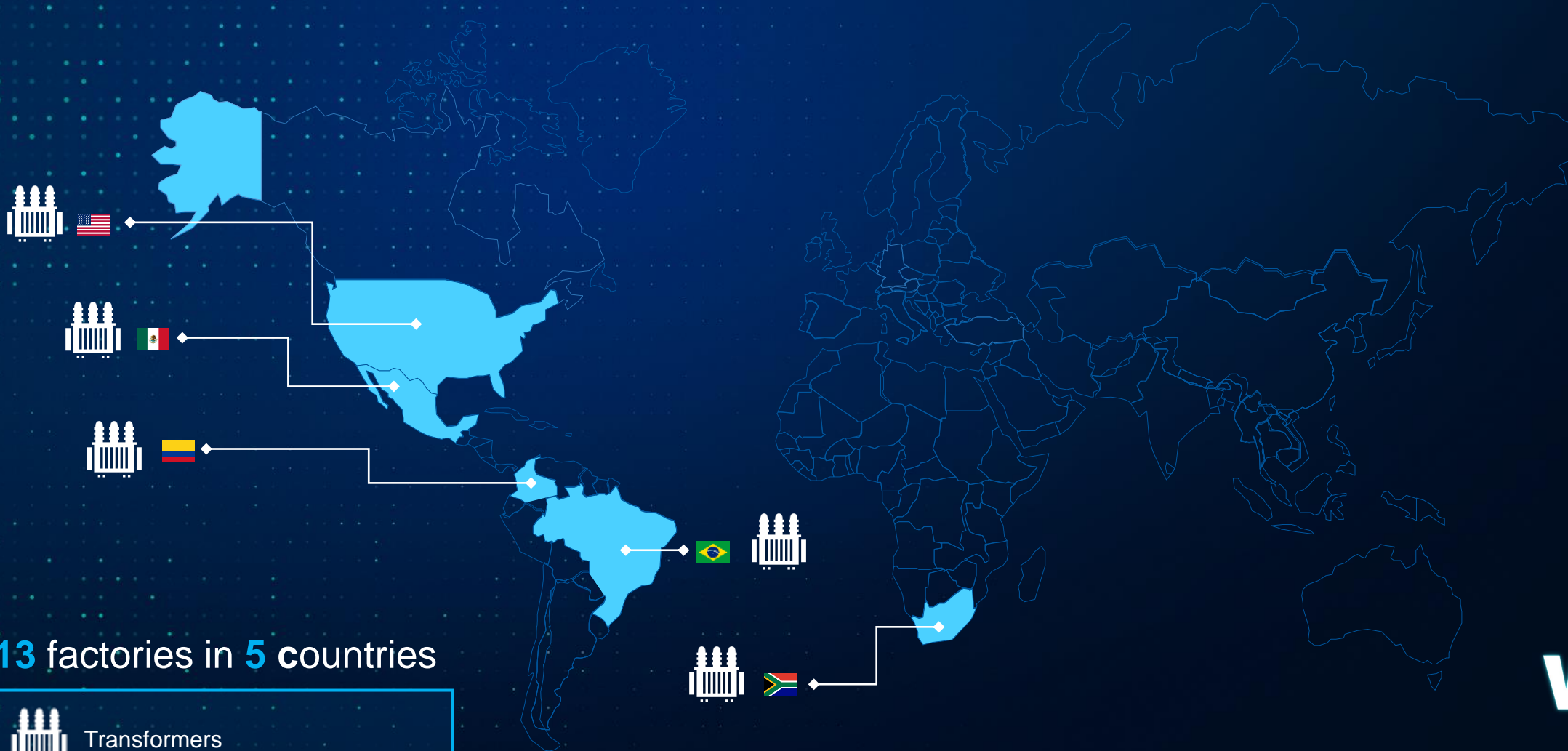

13 factories in 5 countries



Transformers



# Developing Business Strategy



## Renewable Energies



### Expansion:

- US
- India



### Expansion:

- Latin America
- South Africa

## Electric Mobility



### Expansion:

- Latin America
- Europe
  
- Network Integrators
- Sell online
- B2C Promotion
- Automotive Partnerships
- Strategic Partnerships

## BESS<sup>(1)</sup>



### Expansion:

- Latin America
- US

# Electric Mobility WEMOB



**STATION HPC (DC)**  
Launching November 2024



**Global Products**

**Complete recharge ecosystem**



**Pioneer in accredited certification by INMETRO**



# BESS Composition



Two-Way  
Converter

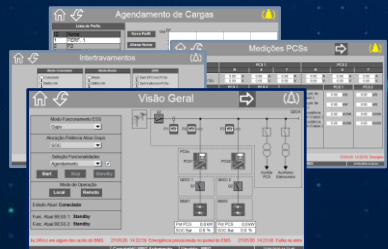

Automation and  
Control System



Transformer  
Medium Voltage /  
Low Voltage



Battery Bank + Management System



Auxiliary  
Systems



- Air conditioning
- Fire system
- Metering

Panels  
Direct Current /  
Alternating Current



# BESS Connection Points

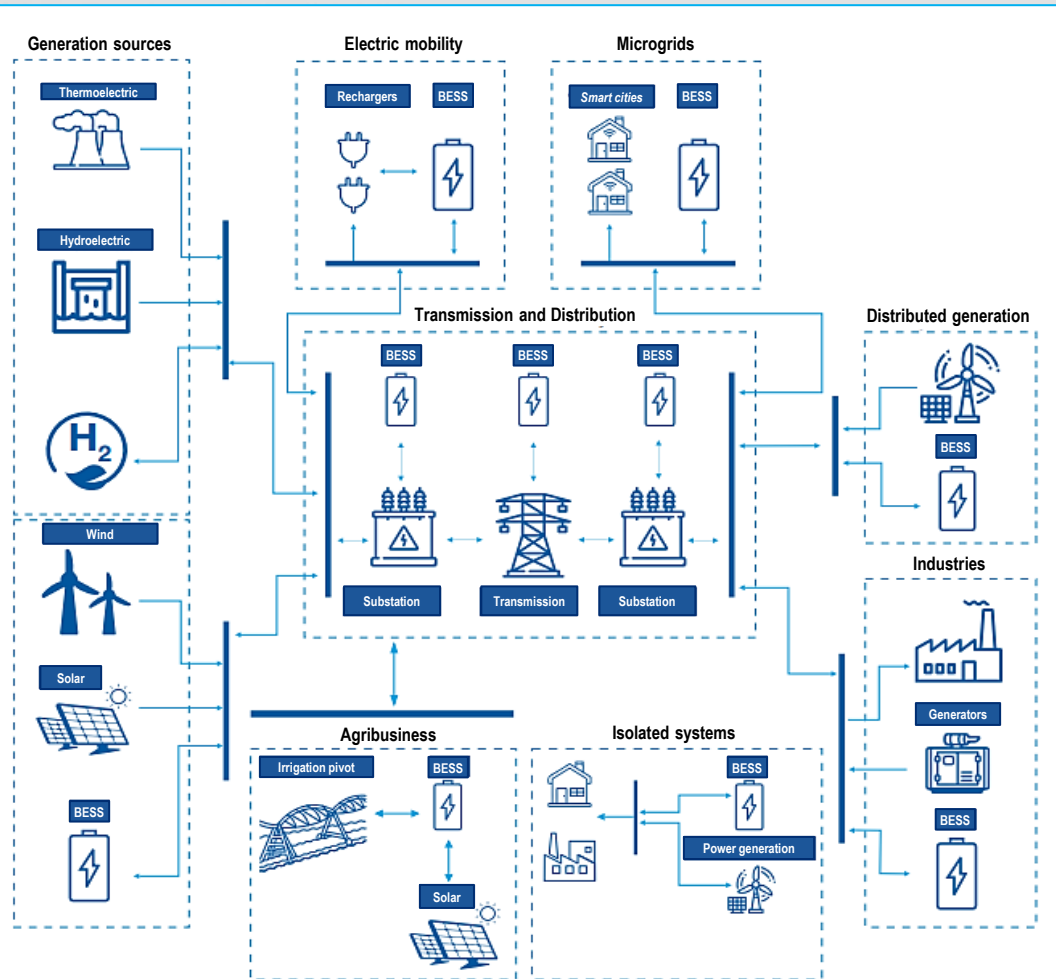

**Connection** at all points in the electrical system

**Configuration** per connection point

Compatible with **generation** sources

# BESS Portfolio



# M&A Strategy



MARKET ACCESS



TECHNOLOGY

\* Acquisition of specific technology or businesses





# WEG Carbon Neutral Program



## WEG Carbon Neutral Program

Reduce GHG emissions by 52% by 2030

Achieve Net Zero by 2050

### Scope 1

- Electrification of natural gas boiler
- Use of biofuel
- Use of electric vehicles
- Process optimization to reduce energy consumption

### Scope 2

- ~90% Renewable Energy consumed in Brazil in 2024
- ~75% of the group's global electricity demand in 2024 from renewable sources

### Projects developed to reduce emissions (2023)

Mapped opportunities	Approved projects	Potential Reduction (tCO2e)
809	610	32,000

## RESULTS

# -25%

Effective reduction of emissions in 2 years

**WEG**  
**DAY**  
2024

# ESG Achievements

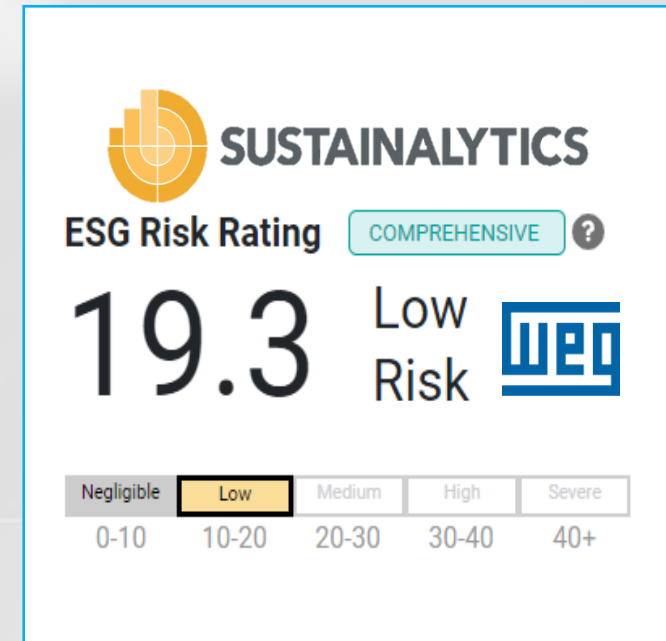
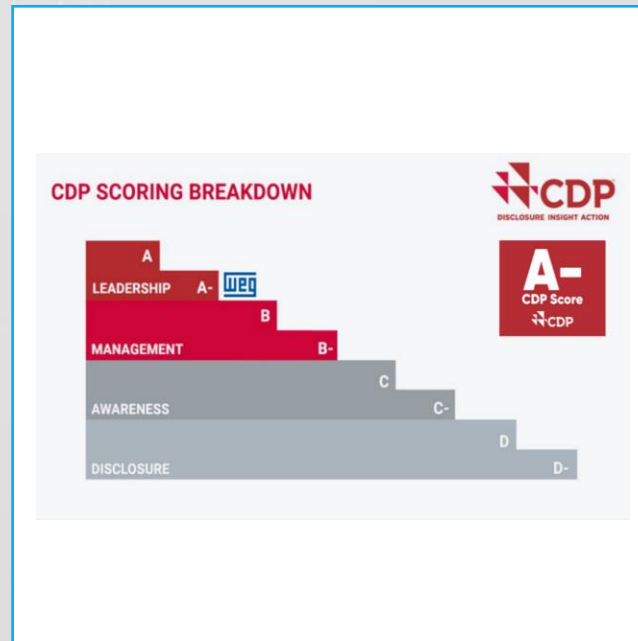

# Key Messages



**Accelerate Internationalization**

Potential opportunities with **Energy Transition** and Use of **AI**

Expansion of the **Electric Mobility** and **BESS** portfolio

Advancing **ESG** projects



**WEG**  
**DAY**  
2024

# Q&A

Driving efficiency and sustainability



# WEG DAY

2024

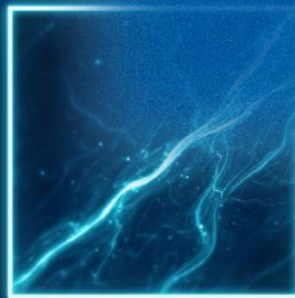

Driving efficiency and sustainability

