

Earnings release – 4Q18 and 2018

Iochepe-Maxion S.A.

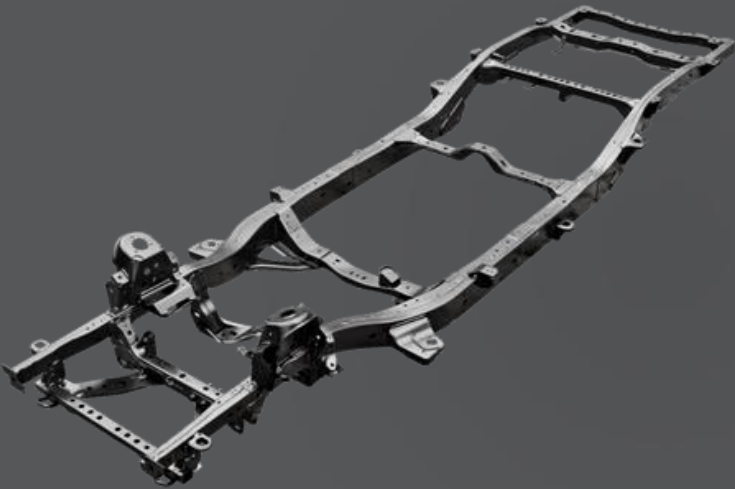

March 12, 2019

## Highlights – 4Q18 and 2018

- Consolidated net operating revenue of R\$ 2,455.8 million in 4Q18 and R\$ 9,616.3 million, an increase of 25.6% compared to 4Q17 and 28.4% compared to 2017
- Revenue from domestic sales of R\$ 605.5 million in 4Q18 and R\$ 2,369.5 million in 2018, an increase of 26.4% and 29.4% over 4Q17 and 2017
- Growth in Reais of 25.4% and 28.1% in revenue from international sales in 4Q18 and in 2018. Excluding the effects of the Exchange rate variation, net operating revenue would have increased 9.2% in 4Q18 and 9.4% in 2018
- EBITDA of R\$ 242.6 million and R\$ 1,057.1 million in 2018, an increase of 22.0% compared to 4Q17 and 32.4% compared to 2017
- Net income of R\$ 76.7 million in 4Q18 and R\$ 201.3 million in 2018, over R\$ 11.8 million in 4Q17 and R\$ 6.4 million in 2017
- Net bank indebtedness of R\$ 2,326.8 million in 4Q18 (R\$ 2,299.9 million in 4Q17). Financial leverage (net bank indebtedness/ EBITDA LTM) decreased from 2.88x at the end of 4Q17 to 2.20x at the end of 4Q18

## Highlights – Subsequent period

- Conclusion of the 9<sup>th</sup> issuance of debentures in February 2019 (subsequent period) in the total amount of R\$ 450.0 million in two series:
  - 1<sup>st</sup> series with a 5-year term and cost of CDI + 0.75% per annum in the amount of R\$ 338.8 million
  - 2<sup>nd</sup> series with a 7-year term and cost of CDI + 0.95% per annum in the amount of R\$ 111.2 million
  
- Conclusion in February 2019 (subsequent period) of syndicated loan in Europe in the amount of EUR 200 million and cost of Euribor (3 months) + 2.75% per annum

## Market performance

### ➤ Automotive Market (units produced)

PRODUCTION Segment	BRAZIL <sup>1</sup>			NAFTA <sup>2</sup>			EUROPE <sup>2</sup>		
	4Q17	4Q18	Var.	4Q17	4Q18	Var.	4Q17	4Q18	Var.
Light Vehicles	727.676	651.695	-10,4%	4.109.460	4.195.440	2,1%	5.255.392	4.950.500	-5,8%
Commercial Vehicles	28.358	33.765	19,1%	134.405	156.860	16,7%	136.832	141.673	3,5%
<b>Total Vehicles</b>	<b>756.034</b>	<b>685.460</b>	<b>-9,3%</b>	<b>4.243.865</b>	<b>4.352.300</b>	<b>2,6%</b>	<b>5.392.224</b>	<b>5.092.173</b>	<b>-5,6%</b>
Agricultural Machinery	10.308	19.483	89,0%	N/A	N/A		N/A	N/A	

Segment	2017			2018			2017			2018		
	2017	2018	Var.	2017	2018	Var.	2017	2018	Var.	2017	2018	Var.
Light Vehicles	2.633.115	2.745.739	4,3%	17.064.157	16.955.103	-0,6%	20.649.998	20.198.908	-2,2%	20.649.998	20.198.908	-2,2%
Commercial Vehicles	103.687	134.070	29,3%	562.920	648.383	15,2%	515.436	528.271	2,5%	515.436	528.271	2,5%
<b>Total Vehicles</b>	<b>2.736.802</b>	<b>2.879.809</b>	<b>5,2%</b>	<b>17.627.077</b>	<b>17.603.486</b>	<b>-0,1%</b>	<b>21.165.434</b>	<b>20.727.179</b>	<b>-2,1%</b>	<b>21.165.434</b>	<b>20.727.179</b>	<b>-2,1%</b>
Agricultural Machinery	42.391	65.656	54,9%	N/A	N/A		N/A	N/A		N/A	N/A	

Source: Brazil (ANFAVEA), NAFTA and Europe (IHS Automotive – light vehicles and LMC Automotive – commercial vehicles)

Europe: considers EU27 + Turkey



# Net Operating Revenue – R\$ million

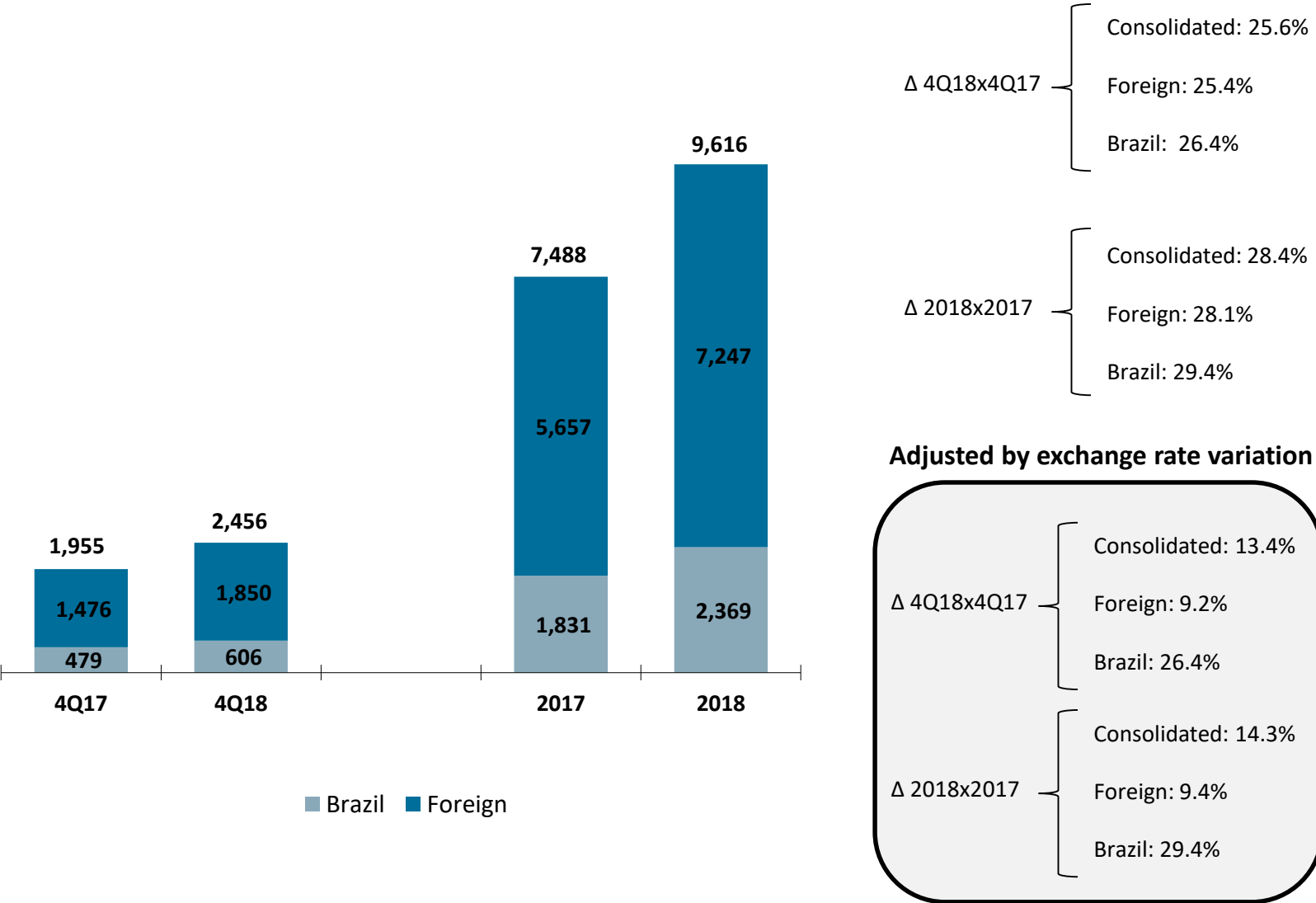

## Net Operating Revenue by Region – R\$ million

<b>Net Operating Revenue- R\$ thousand</b>	<b>4Q17</b>	<b>4Q18</b>	<b>Var.</b>
South America	478,987	605,503	26.4%
North America	513,117	730,830	42.4%
Europe	783,207	879,114	12.2%
Asia + Other	179,333	240,304	34.0%
<b>Total</b>	<b>1,954,644</b>	<b>2,455,751</b>	<b>25.6%</b>

<b>Net Operating Revenue- R\$ thousand</b>	<b>2017</b>	<b>2018</b>	<b>Var.</b>
South America	1,831,325	2,369,451	29.4%
North America	2,127,084	2,812,051	32.2%
Europe	2,872,248	3,512,939	22.3%
Asia + Other	657,282	921,857	40.3%
<b>Total</b>	<b>7,487,940</b>	<b>9,616,299</b>	<b>28.4%</b>

# Net Operating Revenue by Region – (%)

4Q17

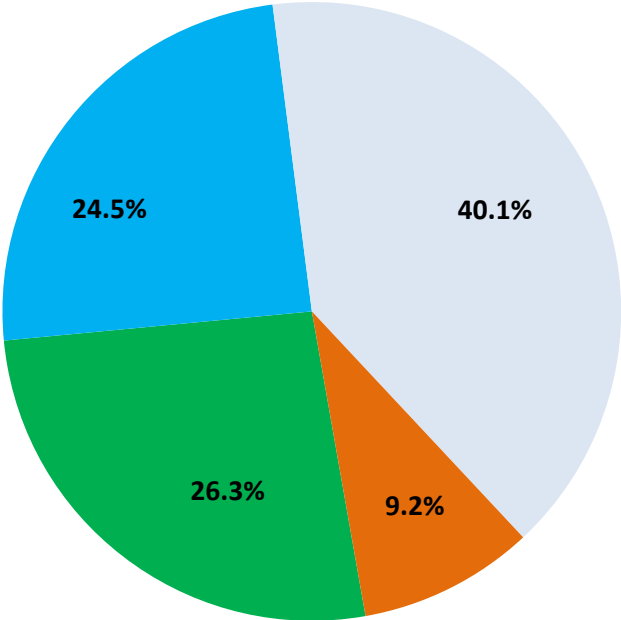

4Q18

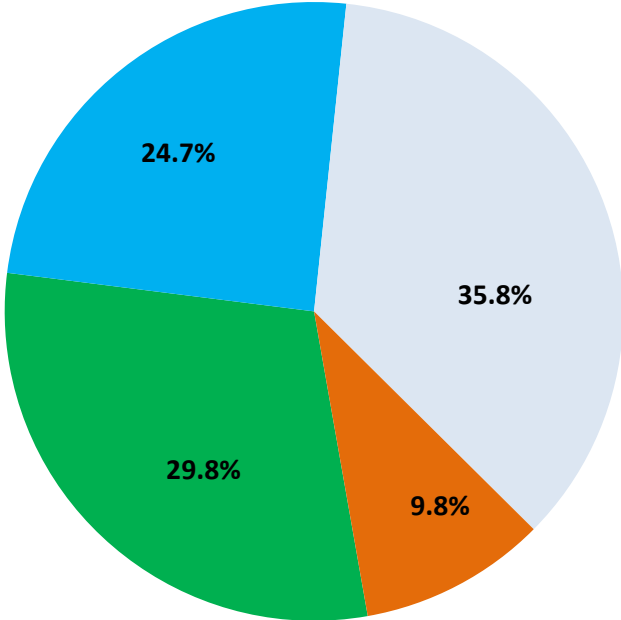

■ North America    ■ South America    ■ Europe    ■ Asia + Others

# Net Operating Revenue by Region – (%)

4Q17

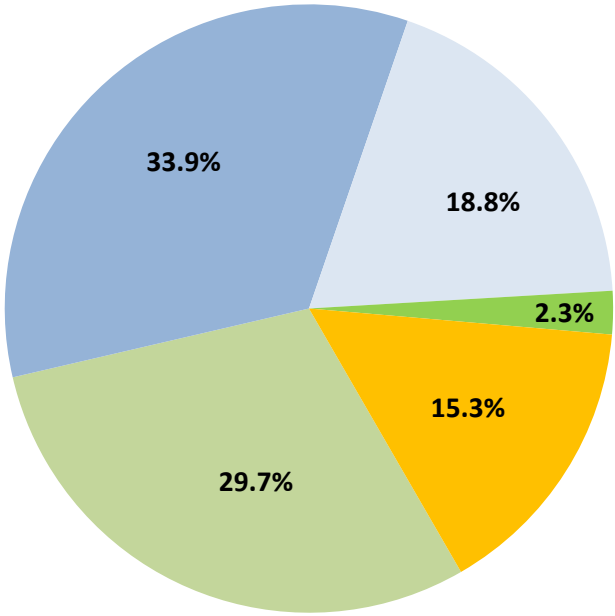

4Q18

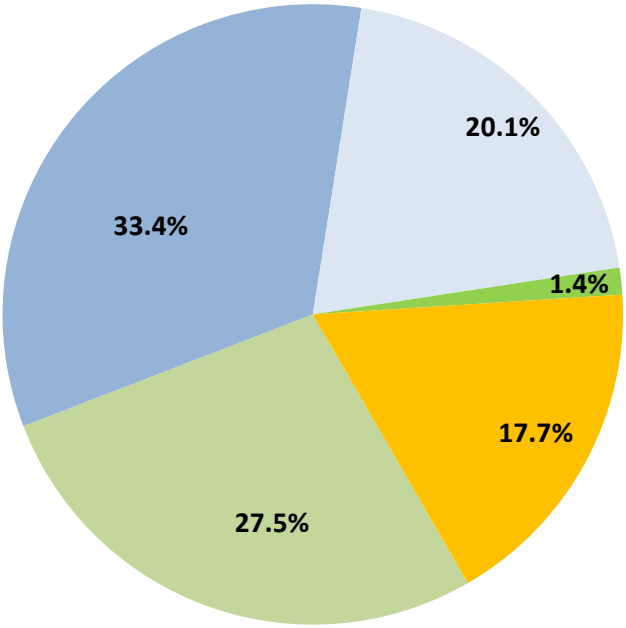

- Light vehicles wheels (steel)
- Light vehicles wheels (aluminum)
- Commercial vehicles wheels (steel)
- Structural Components (light vehicles)
- Structural Components (commercial vehicles)

# Revenue by Customer

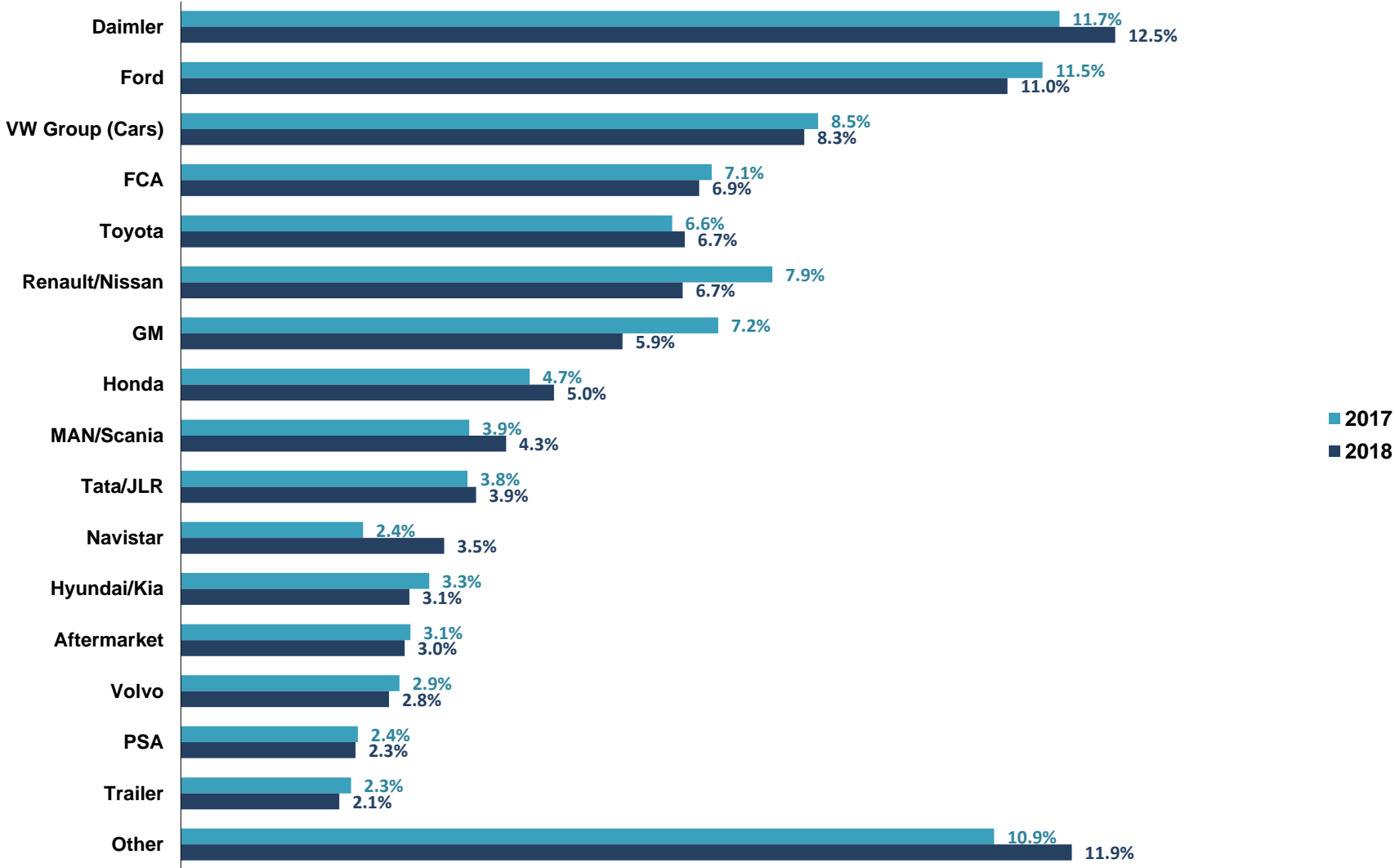

# Gross Profit – R\$ million

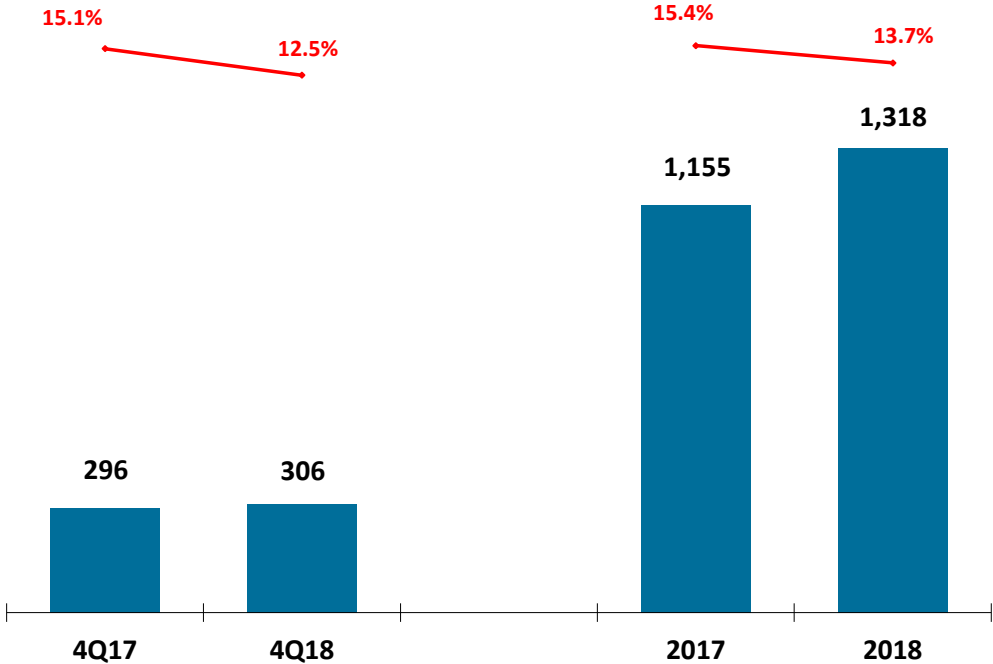

■ Gross profit    — % NOR

➤ Δ 4Q18 – 4Q17 = 3,6%

➤ Δ 2018 – 2017 = 14.1%

<sup>1</sup> Considering the reclassification (CPC47/IFRS15) of freights related to the sales of the line of expenses for the line of costs of goods sold in 2017, the gross margin would have been 13.9% in 2017.

# EBITDA – R\$ million

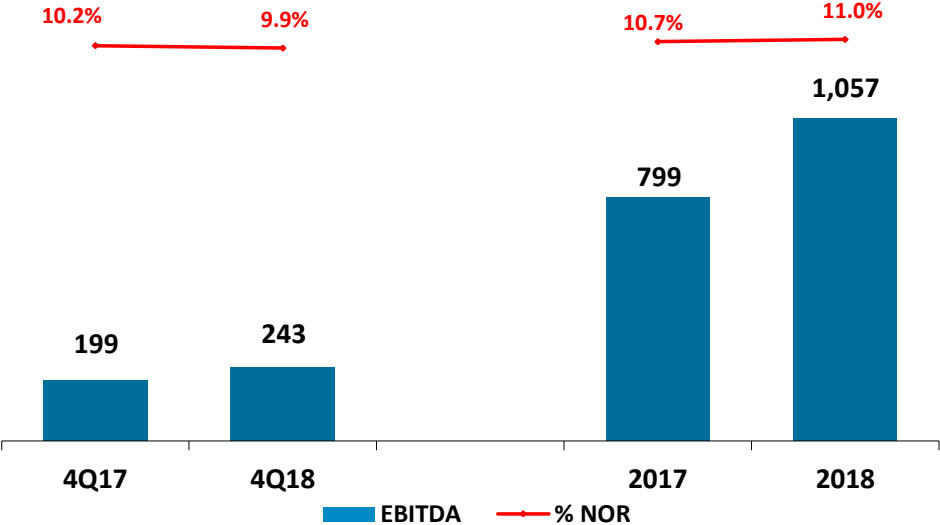

➤  $\Delta$  4T18 – 4T17 = 22.0%

➤  $\Delta$  2018 – 2017 = 32.4%

# Net Financial Expense – R\$ million

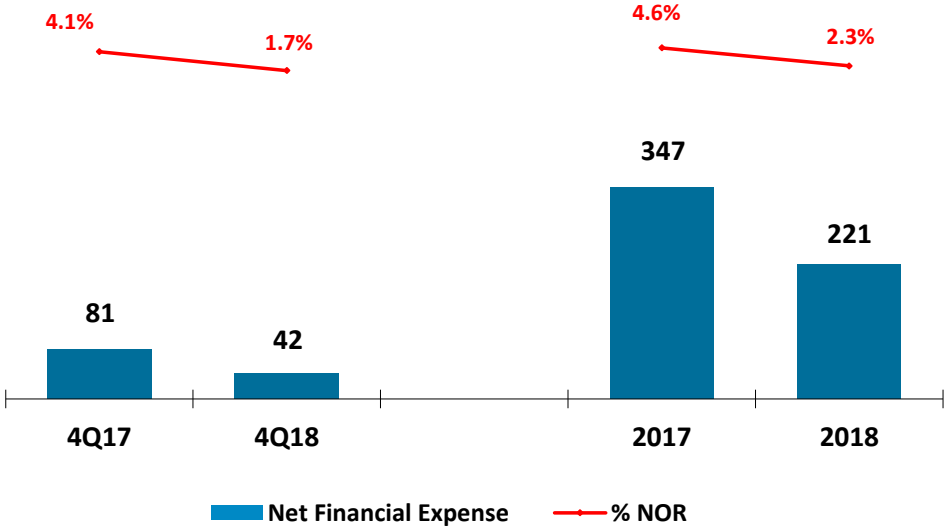

➤  $\Delta$  4Q18 – 4Q17 = -47.7%

➤  $\Delta$  2018 – 2017 = -36.4%

# Net Income – R\$ million

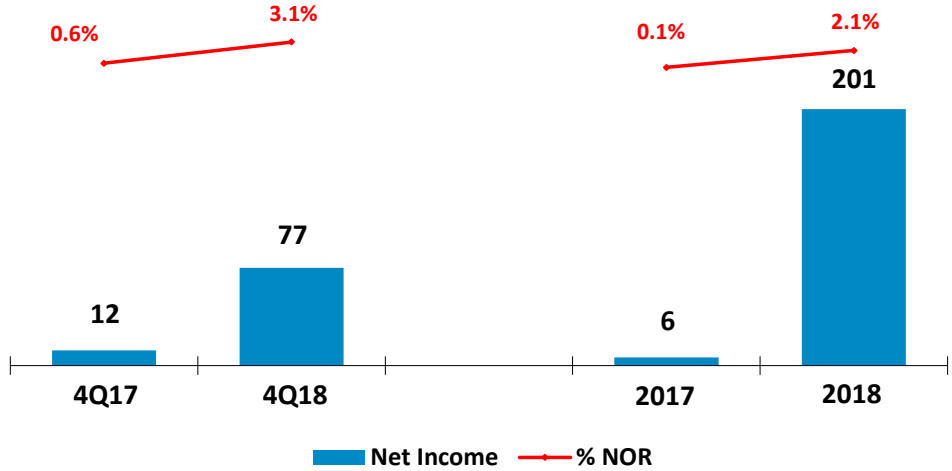

- $\Delta$  4Q18 – 4Q17 = + 64.8 million
- $\Delta$  2018 – 2017 = + 194.9 million

CAPEX – R\$ million

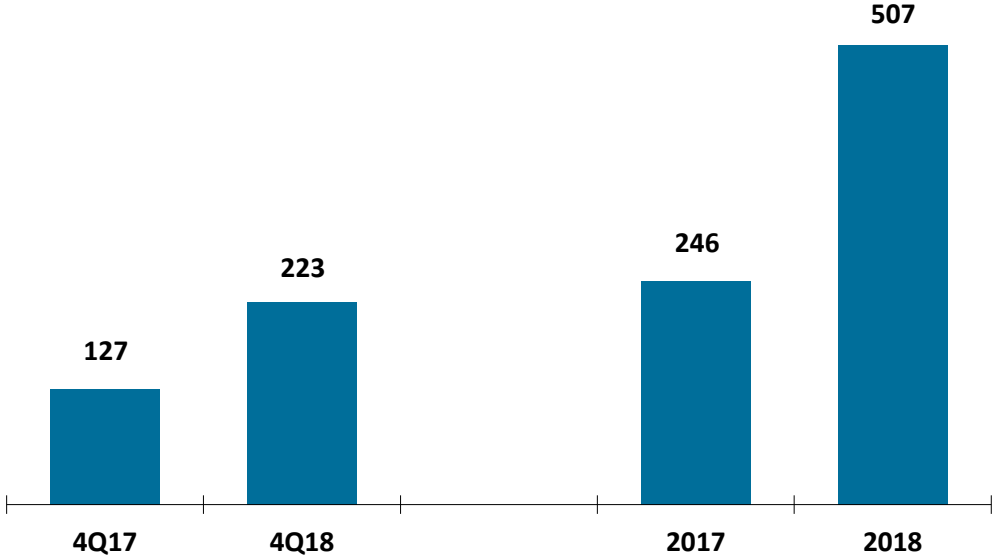

**Main investments in 4Q18:** new aluminum wheel plant unit Project in India and investments in commercial vehicle stamping in NAFTA.

## Indebtedness (4Q18) – R\$ million

	4Q17	4Q18	Var.
Net debt	2.300	2.327	1,2%

Net debt/LTM EBITDA – R\$ million

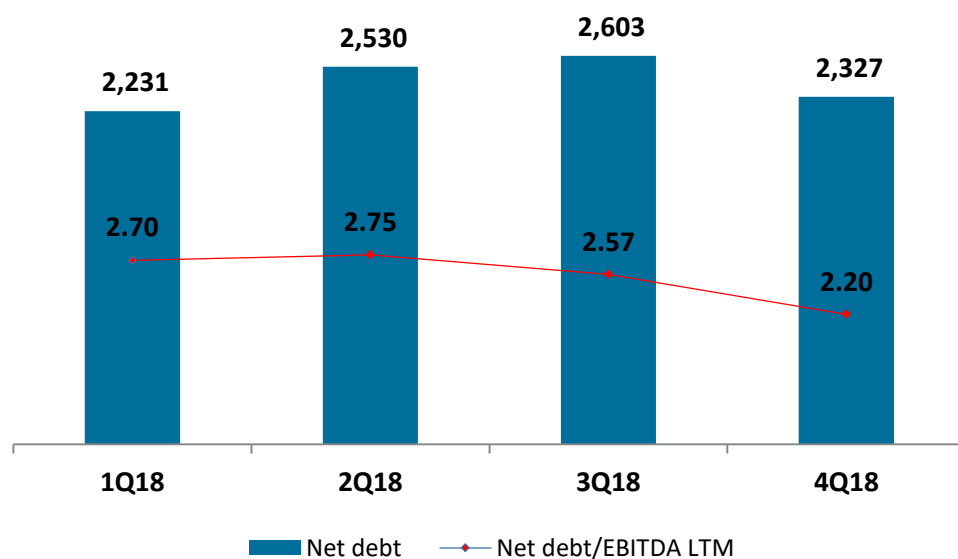

### Average cost

- Indexed in US\$ : US\$ + 6.2% per year
- Indexed in Euro : Euro + 2.9% per year
- Indexed in R\$: CDI + 1.55% per year

### Gross debt

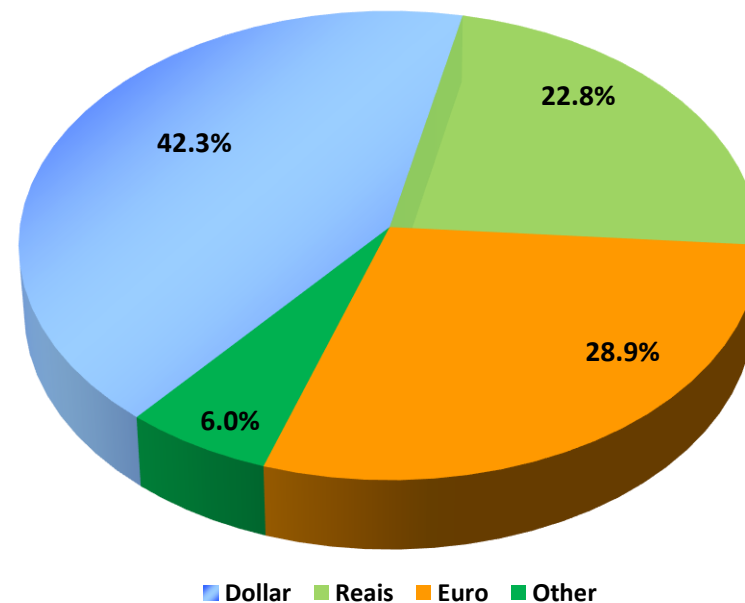

# Indebtedness (4Q18)

Gross debt– 4Q17

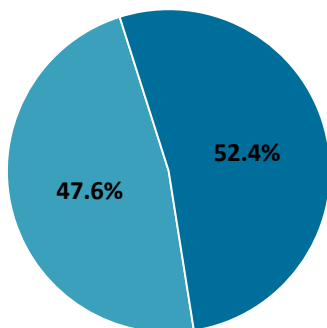

■ Short Term ■ Long Term

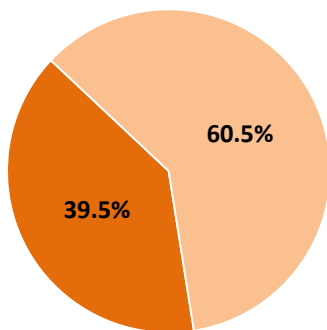

■ Reais ■ Foreign Currencies



Gross debt – 4Q18

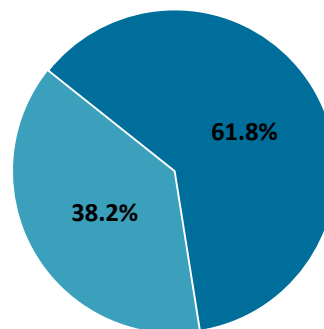

■ Short term ■ Long term

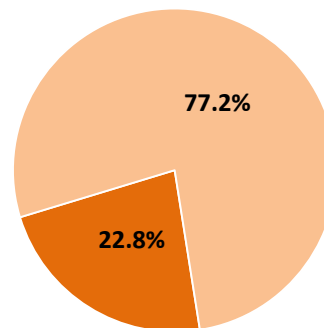

■ Reais ■ Foreign Currencies

Gross debt- 4Q18- **Pro-forma\***

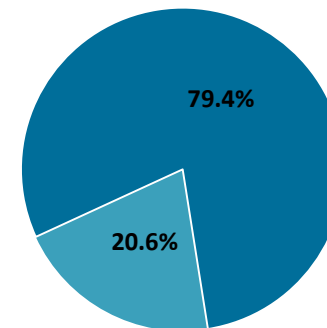

■ Short term ■ Long term

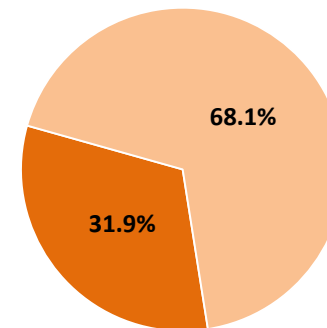

■ Reais ■ Foreign Currencies

- Pro-forma: considers as a subsequent event the two debt refinancing operations carried out in early 2019 (9th issuance of debentures and the new syndicated loan in Europe).

# Capital Markets

Share performance

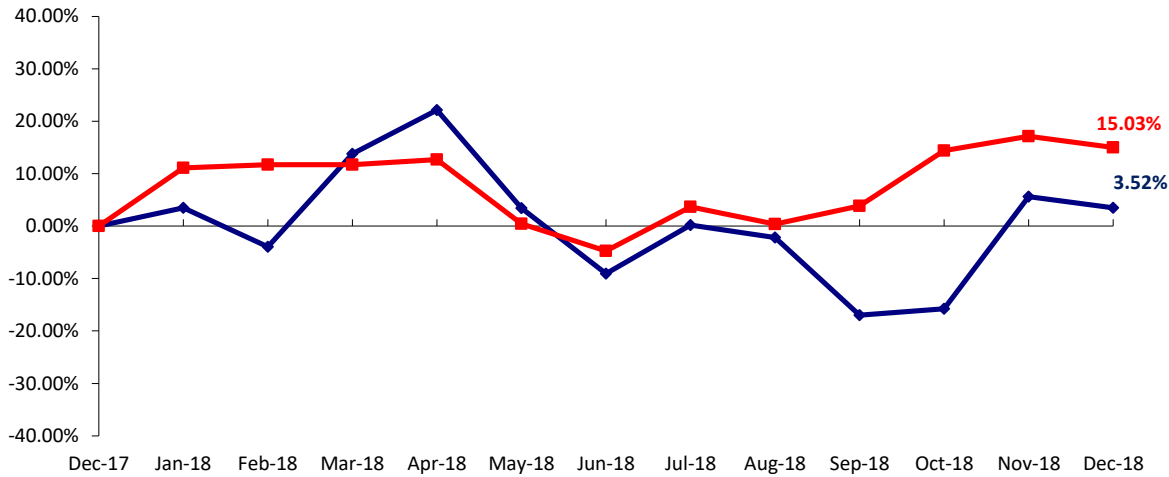

- Number of shares: 150,574,876 (ON-voting)
- Share price on 12/31/2018: R\$ 23.81
- Market Cap on 12/31/2018: R\$ 3,585.2 million

Average Daily Trade Volume

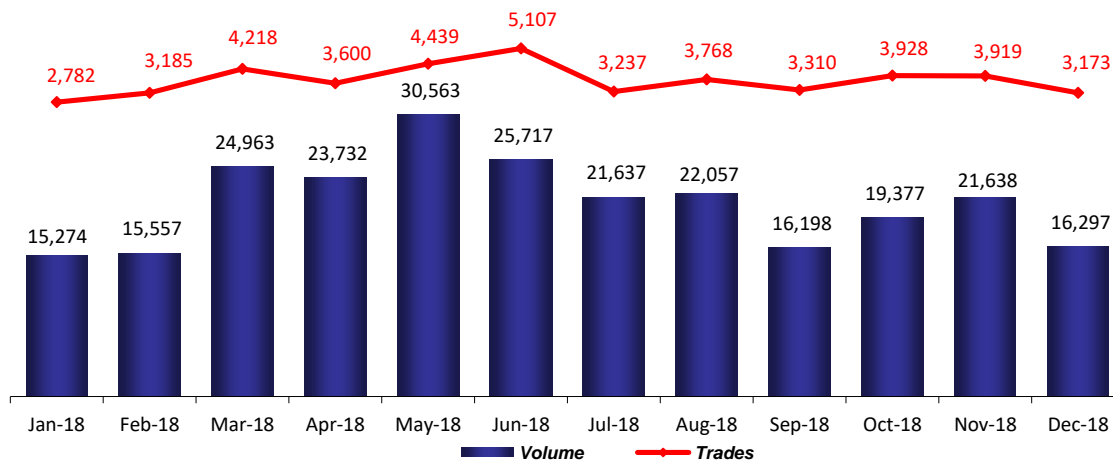

Earnings release – 4Q18 and 2018

Iochepe-Maxion S.A.



March 12, 2019